

OWNER'S MANUAL



CITROËN 

DRIVING		MAINTENANCE		GENERAL INFORMATION	
Instruments on panel	2	Levels, water, oil, LHM fluid	20	General technical characte-	
Controls and accessories	4	Mechanical and electrical systems	22	ristics	36
Openers and locks		Bodywork	24	Engine	38
Doors, boots, bonnet, windows	6	Cleaning	26	Transmission	40
Driving position		REPLACEMENTS		Hydraulic system	41
Seats, steering wheel, rear view		Warning light on instrument		Suspension	42
mirrors, seat belts	8	panel	2	Braking	44
Starting		Replacing a wheel	28	Steering	46
Anti-theft, ignition, choke	10	Replacing a bulb	30	Electrical system	48
Driving		Adjusting the headlamps	32	Bodywork and interior	
Gears, brakes, ground clearance,		Replacing a fuse	33	fittings	52
steering	12	Replacing a battery	34	Running in, checking,	
Signals and visibility		Replacing a sparking plug	34	guarantee	54
Warning lamps, signals,		Replacing "LHM" fluid in		Caravanning	54
windscreen wiper	14	emergency	34	Vehicle identification	55
Air Conditioning		Towing the car	34	Ordering spares	55
Ventilation, heating, cooling,					
de-misting	16				
Accessories					
Ashtrays, sun visor, interior					
lighting	18				

- With the exception of the clock, the instruments function only when the ignition switch is on.

- The panel lighting is controlled by the exterior lighting switch and is adjusted by a rheostat, the button for which is under the steering column, behind the ignition key recess.

1 Speedometer with :

- total mileage indicator
- trip mileage indicator (return to zero : push and turn clockwise)
- stopping distances (see page 13).

2 Electronic tachometer

The needle must not enter the red zone. Do not exceed 4,500 r.p.m. during the first 1000 km (600 miles).

3 Electric Clock

To set : push and turn the button.

4 Water Temperature Thermometer

If, during exceptional effort (example towing uphill), the needle approaches the red zone, reduce the speed and, if stopping, do not switch off immediately but wait until the temperature has dropped.

5 Fuel Gauge

The fuel tank capacity is 90 litres (20 gall. Imp).

6 Engine Oil Temperature Gauge

If the needle enters the red zone, reduce the speed.

If it stays there, consult a Citroen Agent urgently.

7 Hazard Warning Lamp (for certain foreign countries only).

8 Yellow warning lamp, fuel reserve.

When this lamp lights the reserve is less than 10 litres (2 gallons).

9 Blue warning lamp for headlamp main beams

10 Green warning lamp for right - hand flashers.

If it does not function, check the right-hand flashers (see page 30).

11 Yellow warning lamp front brake pad wear

When this lamp lights up on depressing the brake pedal, the brake pads should be renewed as soon as possible.

12 Red lamp, water temperature

If this lamp lights up, stop immediately, then start up your engine and check if radiator fans are turning.

If they are not turning, switch off and allow to cool then drive to the nearest Citroen Agent keeping a watch on the temperature.

If the fans are turning, switch off and check the water level, taking the necessary precautions, then top-up (see page 20).

13 Check switch button for red warning lamps

When this is pressed, the warning lamps (12, 14, 15 and 21) must light up.

This enables a check to be made at any time on the operation of these bulbs. If they do not light, have them corrected without delay.

14 Red lamp, hydraulic brake pressure

This may light up when switching on and may not go out during the first few engine revolutions : wait until it goes out before setting off.

If it lights up en route, stop immediately and go to the nearest Citroen Agent, using the handbrake when necessary.

15 Red warning lamp engine oil pressure

This will light up when switching on and should go out when the engine starts up.

If it lights up en route, stop the engine and check the oil level.

If it lights up despite the correct oil level, stop again and call on a Citroen Agent.

16 Yellow warning lamp, charging

This will light up when switching on and go out as soon as the engine runs. If it lights up en route, call on the nearest Citroen Agent after first checking the alternator and regulator connections.

If this happens at night, avoid using the directional headlamps to economise current.

17 Green warning lamp, left-hand flashers

If they do not operate, check the left-hand flashers (see page 30).

18 Green warning lamp for side lamps

19 Yellow warning lamp for handbrake

This flashes when the handbrake is not completely released.

20 Yellow warning lamp for rear window heater

21 Red warning lamp for imperative stopping

This lights up with any one or more of red warning lights 12, 14 or 15.

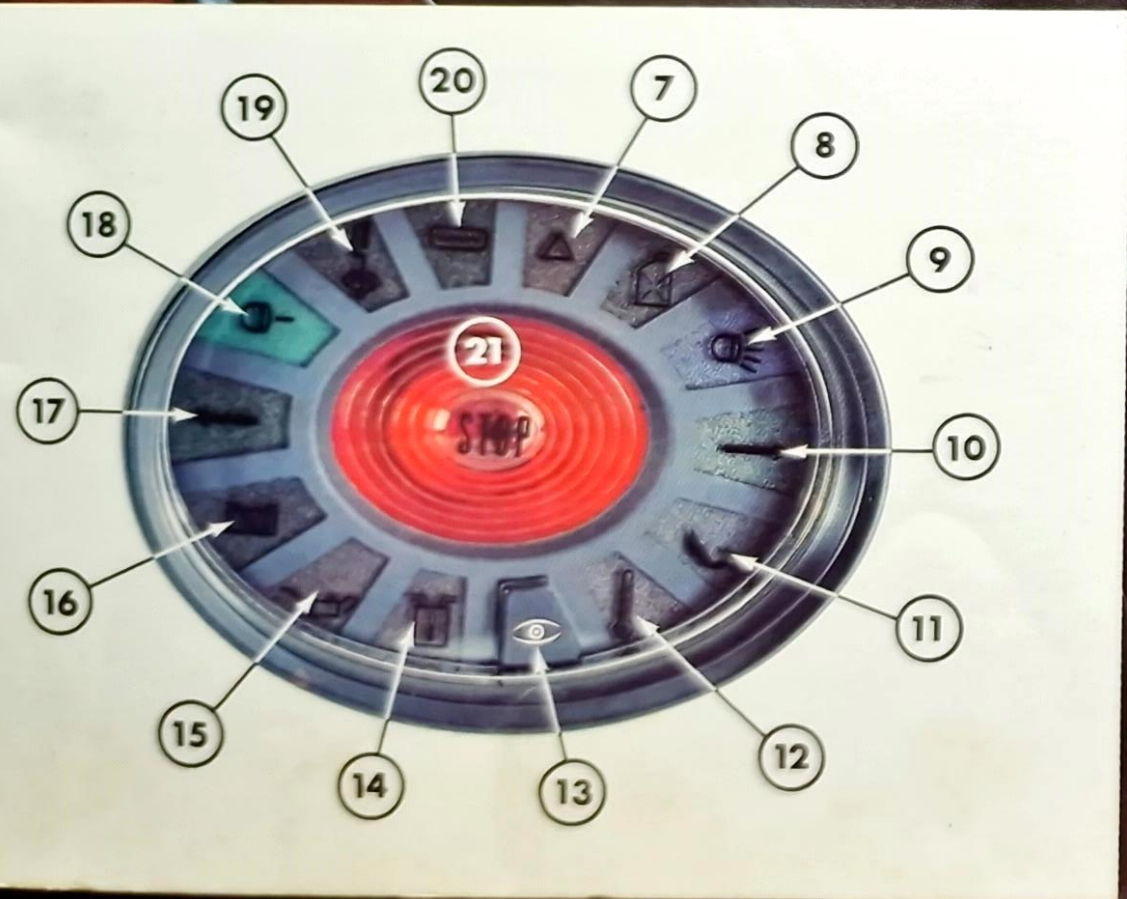
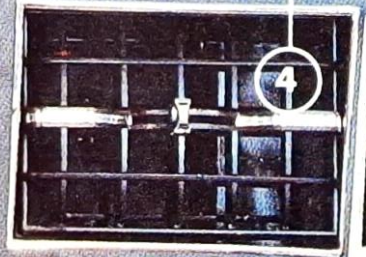
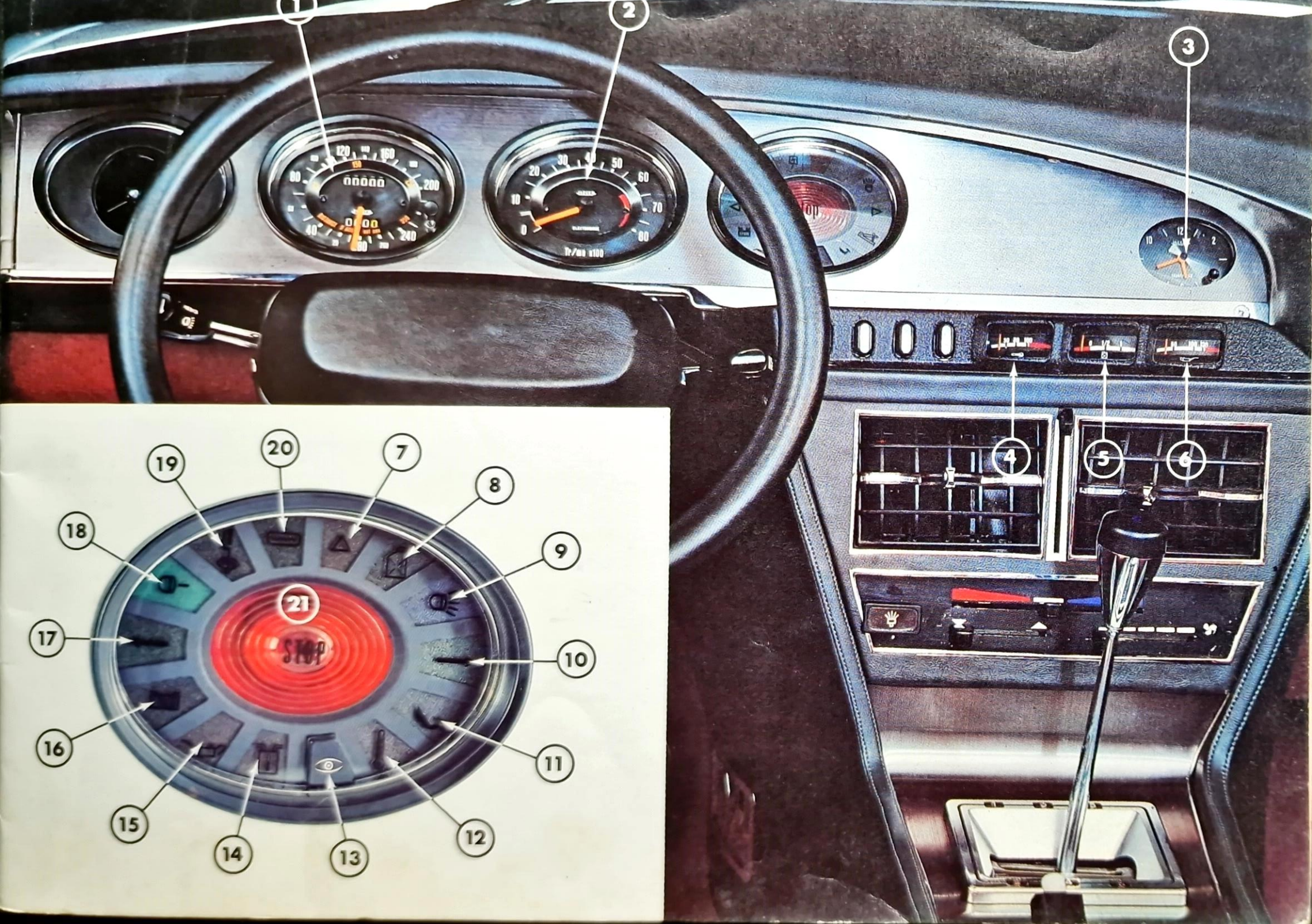

1	Left-hand adjustable ventilator	See page 16
2	Steering wheel	9
3	Switch for lighting	15
4	Switch for fog lamps (option)	15
5	Switch for parking lights	15
6	Switch for electrical heating of rear window	17
7	Switch for interior lighting	18
8	Handle for opening and adjusting output from central ventilation grilles	16
9	Button for opening glovebox	6
10	Right-hand adjustable ventilator	16
11	Switch for direction indicators, horns, and headlamp flashing	14
12	Switch for windscreen wiper and windscreen washer	14
13	Combined anti-theft-ignition-starting switch	10
14	Choke control	10
15	Air distribution, forced, between windscreen and floor	16
16	Switch for electric front windows	7
17	Handbrake lever	12
18	Radio accommodation	18
19	Front ashtray	18
20	Cigar lighter	18
21	Gear lever	12
22	Ventilator control	16
23	Adjustment of forced air temperature	16
24	Control for angular adjustment of ventilator grille	16
25	Map reading lamp	18

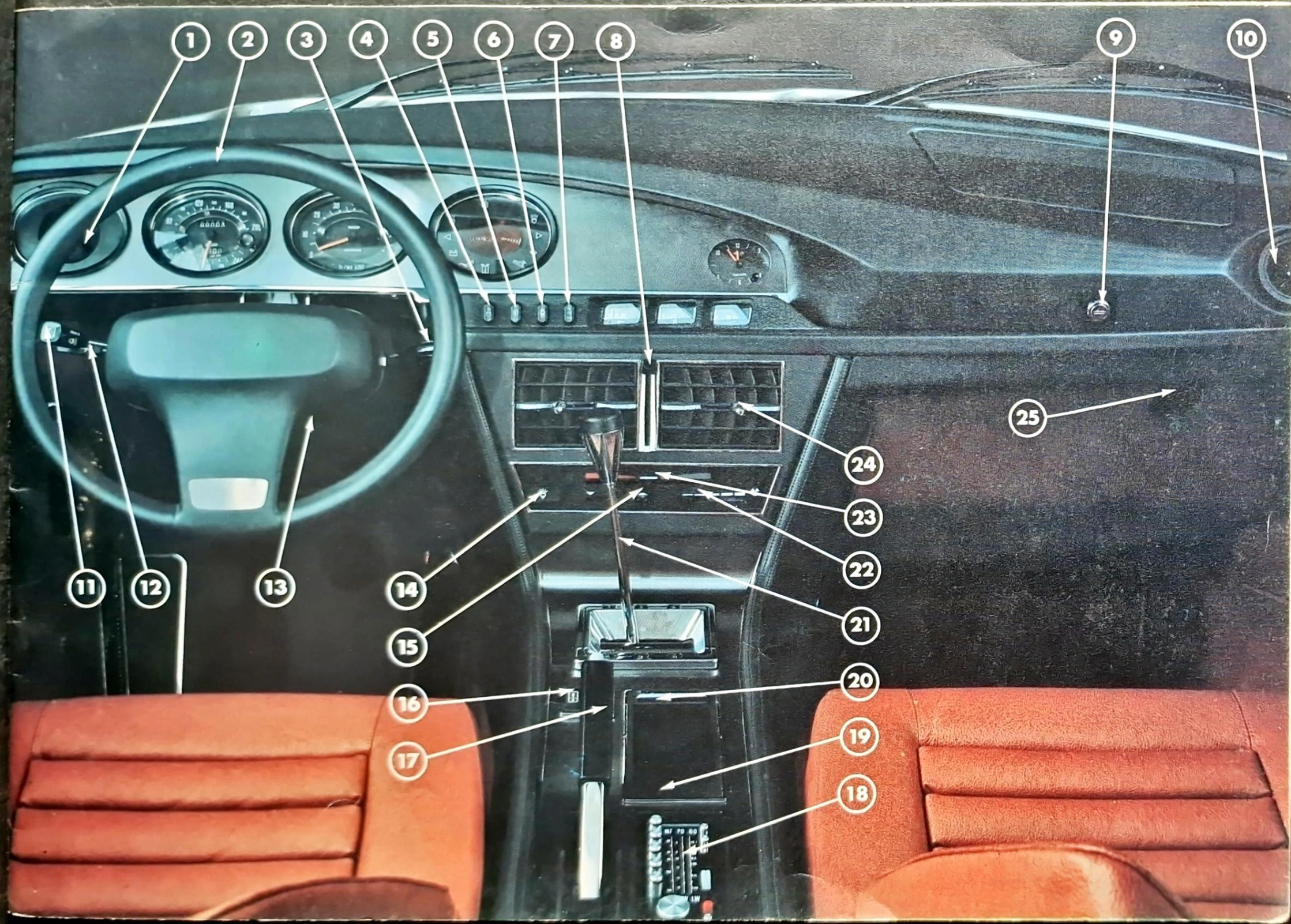

1

2

3

4

5

6

7

8

9

10

11

12

13

14

15

16

17

24

23

22

21

20

19

18

25

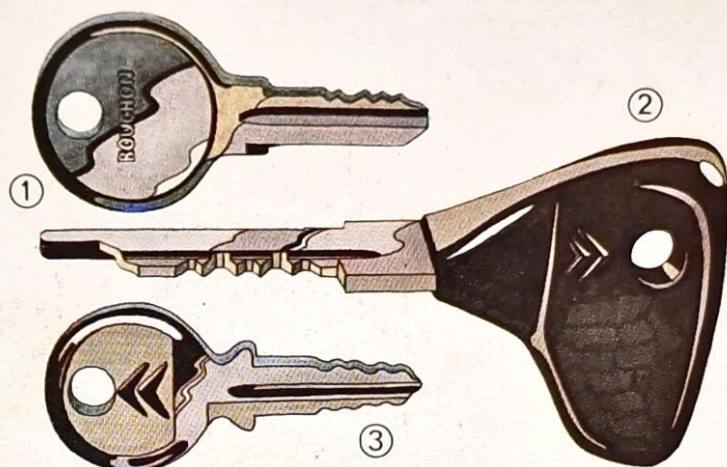

Fig. 3 - Keys

- 1 - fuel filler
- 2 - ignition
- 3 - side doors,
rear luggage boot,
glovebox.

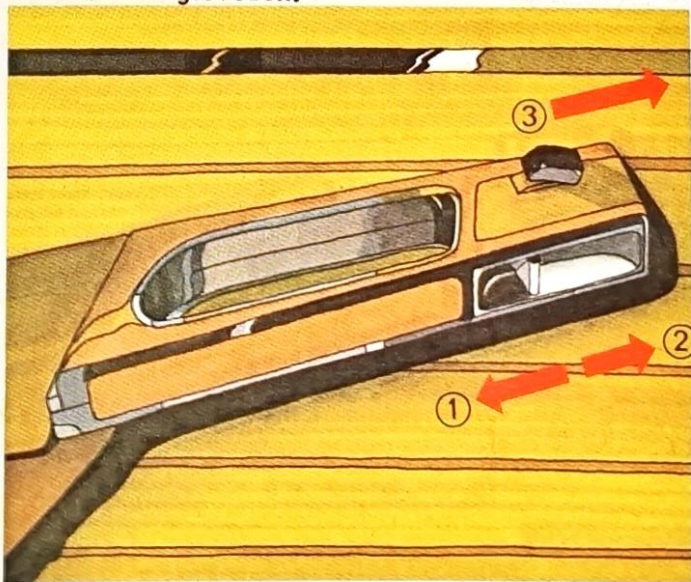

Fig. 4 - Interior handle
1 - opening.

Keys (Fig. 3)

The key bearing the inscription "BOUCHON" is for opening the fuel filler (see page 7).

The largest key is for the combined anti-theft ignition starter (see page 10).

The third key locks the side doors, the rear boot and the glovebox.

We recommend that note be taken of the numbers of these keys in the "Maintenance Guide" which accompanies this booklet.

Side doors

From the outside : to open, raise the handle.

From the inside : to open, move the catch towards the rear.

Opening the doors operates the interior lighting and the lighting for the combined anti-theft ignition starting.

Glovebox

To open : press the button in front of the passenger.

This button may be locked with the key for the side doors.

Opening the lid illuminates the glovebox.

Rear boot

To open : press the button under the numberplate and lift the boot lid which will remain in place automatically.

To close : lower the boot lid and press lightly.

The button may be locked with the key for the side doors.

Opening the boot lid illuminates the boot.

DOORS, BOOT, BONNET, WINDOWS.

7

Front side windows (Fig. 5)

These are controlled by two rocker-switches on the central console, in front of the handbrake.

Each switch controls the glass on the same side.

To raise a window : press the front of the toggle.

To lower a window: press to the rear.

Rear Side Windows

To open : turn the knurled button in an anti-clockwise direction.

To close : turn in the other direction.

Engine bonnet (Fig. 6)

To open : Pull the knob on the left of the driver under the facia panel and the bonnet will open slightly.

Slide the hand under the bonnet, in the centre, and push the safety lever.

Open fully and allow to drop slightly : the bonnet will remain in position automatically.

To close : Slightly raise the bonnet to free the supporting stay.
Opening the bonnet illuminates the engine compartment.

Fuel filler

This is on the right-hand side of the vehicle.

To open the cover, press on the rear to release.

The plug is locked by the key marked "BOUCHON" which can only be withdrawn in the closed position.

To close the cover, press lightly.

Fig 5 - Window controls

A - left-hand window
B - right-hand window
1 - raise
2 - lower

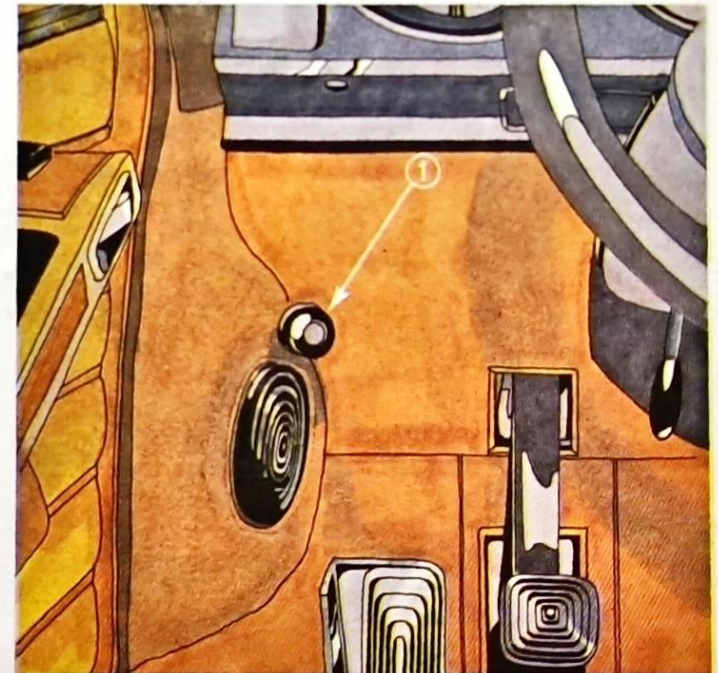
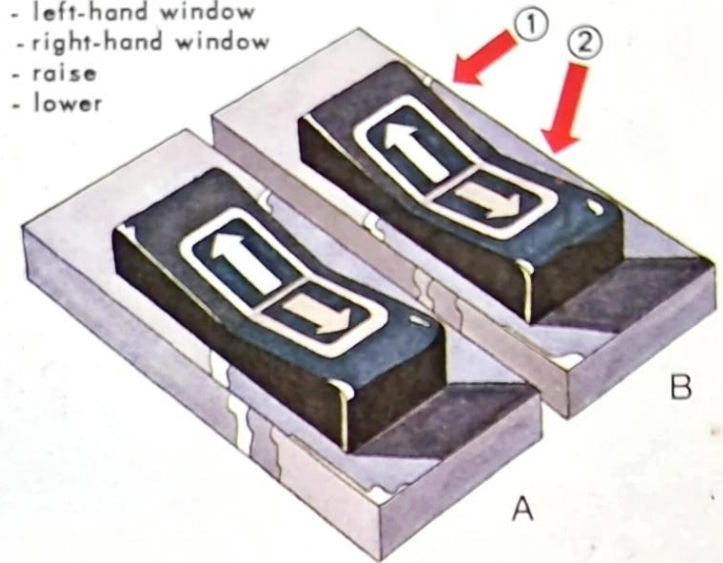
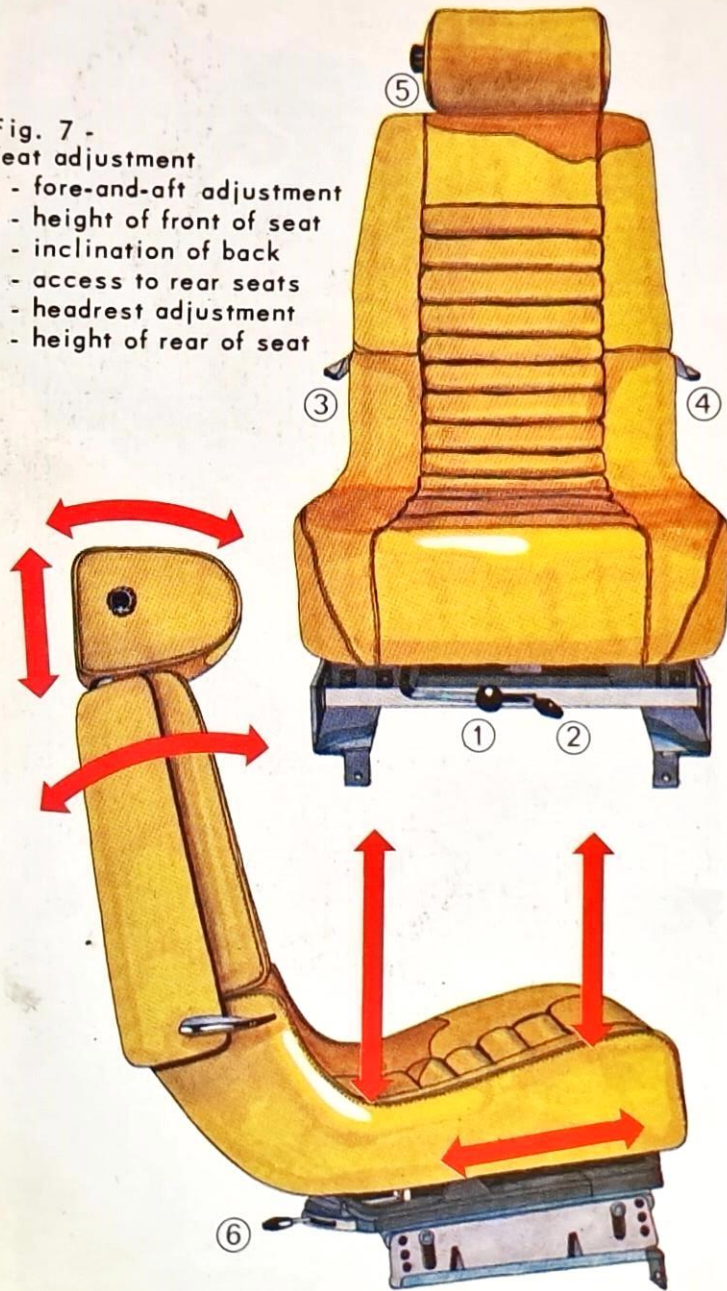

Fig 6 - 1 - Knob for unlocking the bonnet

Fig. 7 -
Seat adjustment
1 - fore-and-aft adjustment
2 - height of front of seat
3 - inclination of back
4 - access to rear seats
5 - headrest adjustment
6 - height of rear of seat



Fore-and-aft adjustment of the seats (Fig. 7 - Item 1)

The locking lever of the seat is situated at the front, right hand side.

Raise this for moving the seat.

Release it to lock the seat in the desired position.

Back rest inclination (Fig. 7 - Item 3)

The locking lever for the back rest is situated on the side towards the inside of the vehicle.

Hold this down whilst pushing with or easing the back until the desired inclination is achieved.

Height and angle of the seat (Fig. 7 - Items 2 and 6)

The knob situated on the front left-hand side of the seat, pushed towards the left, enables the front of the seat to pivot to one of the three possible heights.

The knob situated at the rear of the seat, pushed towards the right, allows the rear of the seat to pivot to one of the three possible heights.

Adjustment of the front may be carried out whilst seated.

Access to rear seats (Fig. 7 - Item 4)

The lever on the side of the back rest, towards the outside of the vehicle, allows access to the rear without upsetting the seat or back rest adjustments.

When this lever is lowered, the back rest pivots and the seat, unlocked, may be pushed towards the front.

It is sufficient to push the seat towards the rear for it to automatically position itself.

Headrest Adjustment (Fig. 7 - Item 5)

Turn the knob on the right-hand side of the headrest to move it backwards or forwards.

It is also possible to raise the headrest by pulling it upwards.

Adjusting the steering wheel (Fig. 8)

Pull the lever situated under the steering head, on the left-hand side.
Adjust the position of the steering wheel vertically and fore-and-aft.
Push the lever fully towards the front.

Interior Rear View mirror

The lever found under the base of the rear view mirror enables it to be changed to the day or night position without changing its alignment.

Day : lever pushed towards windscreen.

Night : lever pulled towards driver.

Seat Belts (Fig. 9)

To secure : insert the end of the plain buckle in the lever buckle.

To release : raise the lever.

To adjust : modify the length of the short belt (towards the centre of the car) by sliding the belt in the adjusting clip ; the harness should be adjusted on the body without being too tight.

Citroen Agents are at your disposal to fit seat belts to the rear seats.

Driving position

Adjust the fore-and-aft position of the seat as well as its height and angle to suit the controls.

Then adjust the back rest angle and steering wheel position according to driving style.

Place the head rest in position.

Adjust the rear view mirror after determining the best driving position.

Then fit the seat belt and adjust its length.

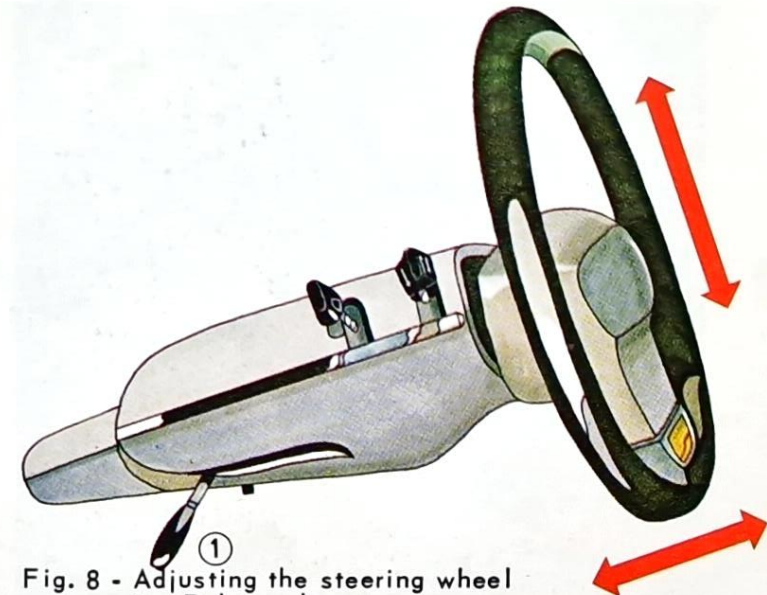

Fig. 8 - Adjusting the steering wheel
1 - Release lever

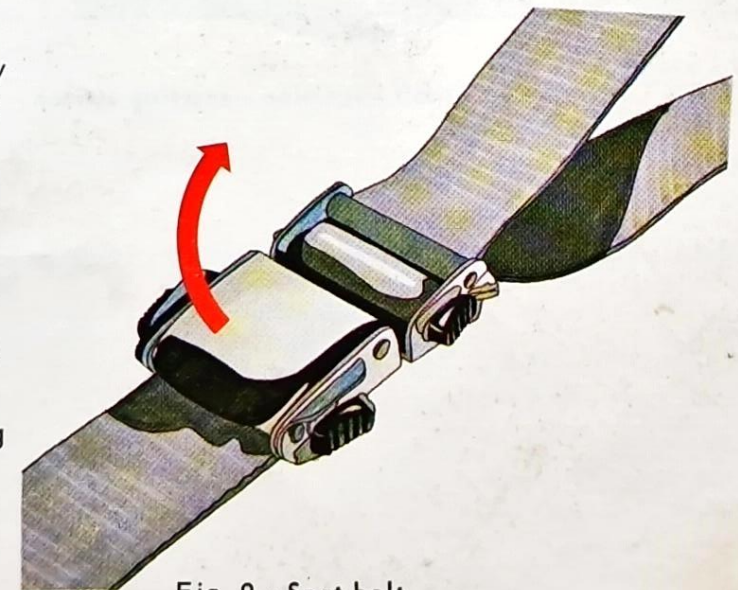

Fig. 9 - Seat belt

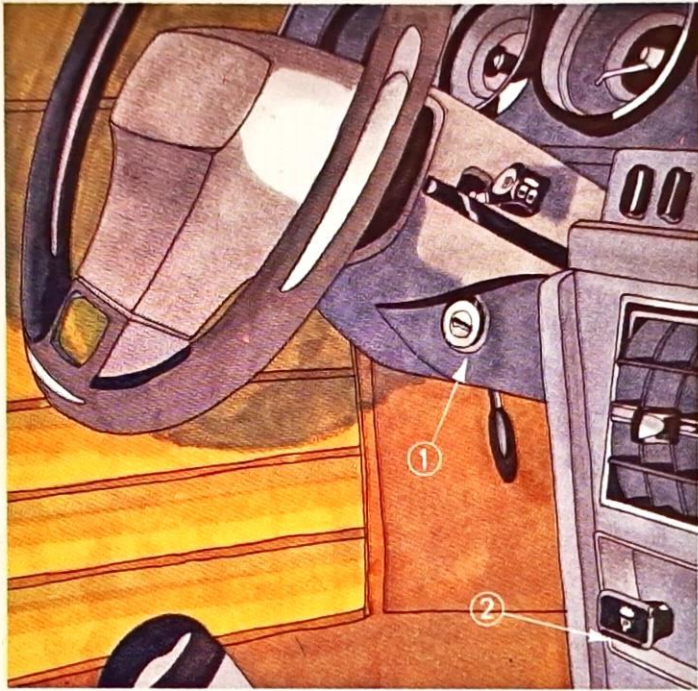

Fig. 10 - Starting

- 1 - Combined anti-theft - ignition - starting switch
- 2 - Choke control

Combined anti-theft ignition starting switch (Fig. 10 - Item 1)

The key position is found on the right side of the steering head and is automatically illuminated when the doors are open.

To illuminate when the doors are shut, press the interior lighting switch.

The successive positions of the key, when turning in a clockwise direction (Fig. 11) are as follows :

- 1 - anti-theft (steering locked)
- 2 - garage (steering free)
- 3 - ignition on.
- 4 - starter

It may be necessary, when moving from the position "antivol" to the position "garage" to move the steering wheel slightly whilst turning the key.

The key must be released as soon as the engine starts up.

If the engine stops, or it will not start at first, the ignition must be switched off before attempting to start a second time (this is due to a safety device which prevents operating the starter motor when the engine is running) .

To withdraw the key, pull lightly when near the chosen position ("antivol" or "garage") .

Never withdraw the key until the car is completely stopped.

Choke (Fig. 10 - Item 2)

This is situated under the central console, to the left of the fresh air controls.

Use this only when the engine is cold and push it in fully when the engine is running normally.

Starting

Do not touch the accelerator pedal.

Ensure that the gear lever is in neutral.

Turn the key until the warning lamps for charging, oil pressure and finally hydraulic fluid pressure are illuminated ; the ignition is on.

If the engine is cold :

Pull the choke control fully.

Operate the starter without touching the accelerator.

If the engine does not start the first time, switch off and wait three or four seconds before trying again.

Push in the choke as soon as the engine is running normally.

After a long period in the garage or after running out of petrol, switch on and wait three or four seconds before operating the starter motor.

If the engine is warm or hot :

Operate the starter whilst pressing progressively on the accelerator.

If the engine does not start at the first attempt, switch off, wait three or four seconds and try again.

Before engaging first gear

Do not race the engine.

Allow the engine to run a short time, for the car to reach its normal running height.

The warning lamps for charging and engine oil pressure should have gone out.

If the hydraulic fluid pressure warning lamp is on, wait for it to go out before starting off.

Do not run the engine in an enclosed space.

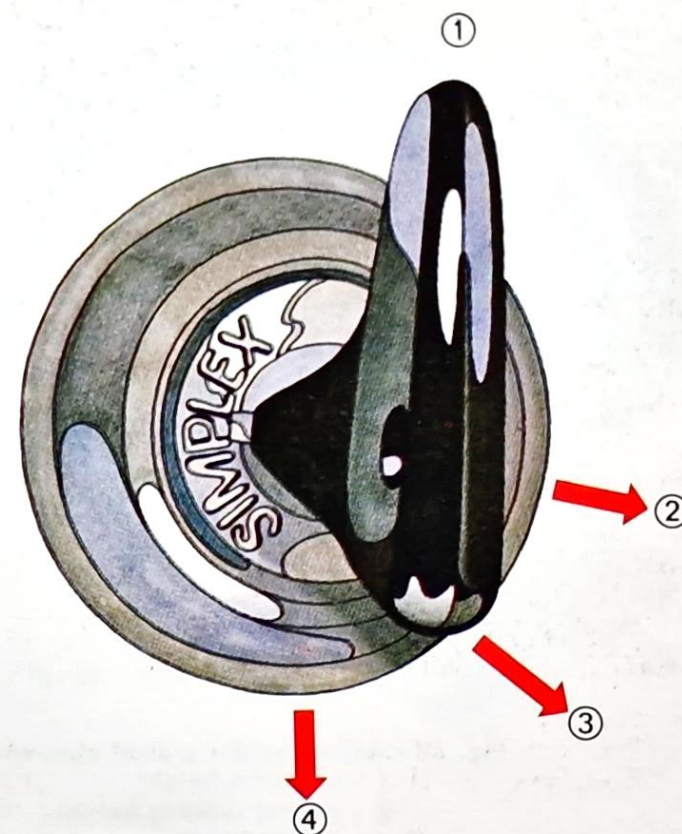

Fig. 11 - Combined anti-theft ignition starter switch
 1 - Position "Anti-theft"
 2 - Position "Garage"
 3 - Ignition
 4 - Starter

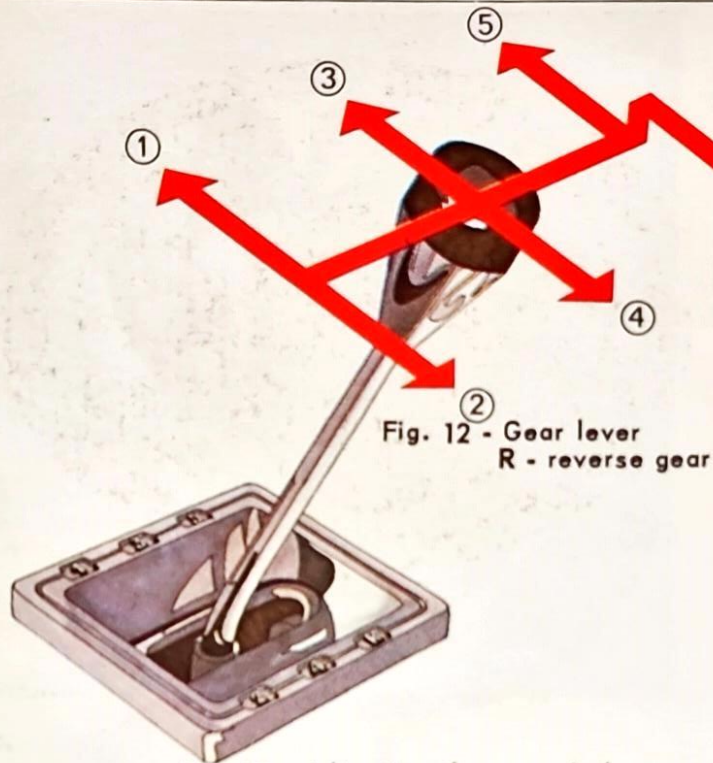

Fig. 12 - Gear lever
R - reverse gear

Gear Change Lever (Fig. 12)

The gear positions are marked on the lever base, reverse gear bearing the letter "R".

To engage reverse gear :

- Ⓡ wait until the car is stationary
- raise the lever then engage the gear.

The engagement of reverse gear illuminates the reversing light.

Handbrake

To apply : pull towards the rear.

To disengage : pull again, pressing the button meanwhile, then push towards the front.

A yellow warning lamp flashes in the central warning cluster when the brake is on or is not sufficiently released.

Fig. 13 - Adjusting the ground clearance

- 1 - minimum height
- 2 - normal running height
- 3,4 - height for special roads
- 5 - maximum height

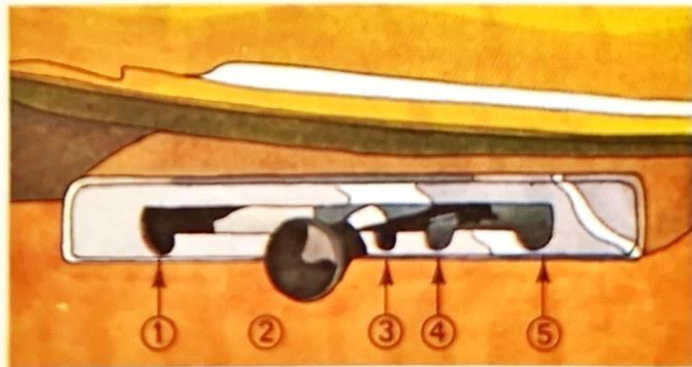

Adjusting the ground clearance (Fig. 13)

The control, situated on the left-hand side of the driver's seat, enables five different car heights to be selected. It is telescopic for ease of manoeuvre.

The normal running position, ensuring maximum comfort, is obtained in the second notch from the front, marked with a line. The two following notches are for use on difficult roads.

The end notch at the front corresponds to the minimum height position, the end notch at the rear to the maximum height position. These two positions, provided for wheel changing (see page 28) must not be used for normal running.

It is nevertheless possible in exceptional circumstances to use the maximum height position with care and for a short distance over particularly difficult surfaces.

Care of main brakes

Two warning lamps in the central warning cluster check the main brake.

- the yellow warning lamp for the front brake pads lights up, when applying the brakes, when brake pad wear necessitates renewal.
- the red warning lamp for hydraulic fluid pressure is a signal requiring immediate stopping of the car, then proceed slowly and carefully to a Citroen Agent using the handbrake instead of the foot brake.

Stopping distances (Fig. 14)

The hydropneumatic suspension, good road holding with faultless steering, allow the employment of full engine power, and require particularly efficient brakes.

However, whatever the system of braking, it remains essential to remember that at any moment stopping distances increase considerably with the speed.

For this reason we have inserted some of these on the speedometer. These are always based on the supposition that the tyres are in good condition, the car not over-loaded, and average road-adhesion as well as normal reflexes on the part of the driver.

These distances may be very much greater in other conditions, notably on wet or greasy ground.

Steering

Power assisted steering, designed for greater security at high speed and ease of steering, is on the one hand very direct, and possesses, on the other hand, a power-centering device in town so that the wheels may return to straight line position, even when stopped, when one releases the steering wheel.

This should be taken into account when manœuvring and parking.

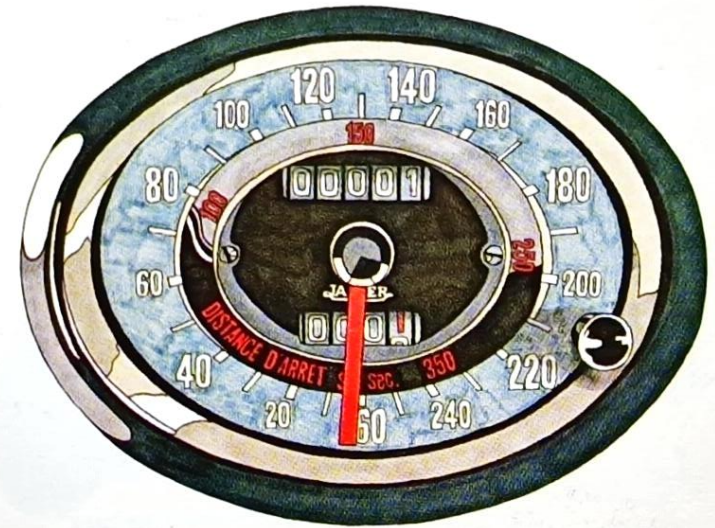

Fig. 14 - Speedometer with stopping distance reminder

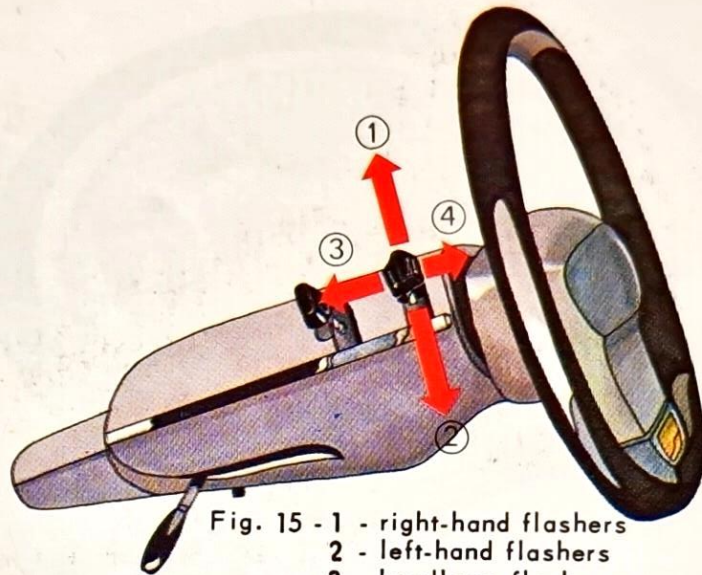

Fig. 15 - 1 - right-hand flashers
2 - left-hand flashers
3 - headlamp flashers
4 - horns

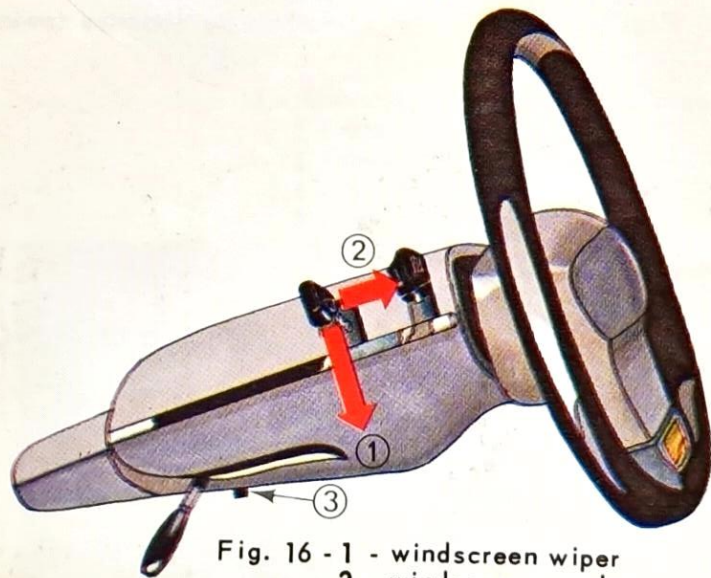

Fig. 16 - 1 - windscreen wiper
2 - windscreen washer
3 - intermittent windscreen wiper

Switch for direction indicators, horns, headlamp flasher (Fig. 15)

Direction indicators

Right-hand flasher : pivot the lever upwards

Left-hand flasher : pivot the lever downwards

The corresponding green warning lamp should flash in the warning cluster, accompanied by an audible signal.

If it does not flash, check the direction indicators (see page 30).

Headlamp flasher.

To flash headlamps : push the lever towards the front. The headlamps will remain on so long as the lever is pushed.

This control works when the lever is in any of the direction indicator positions, Right, Off, or Left.

Horns.

Moving the lever towards the driver operates the first horn, then by pulling further, the loud horn.

Switch for windscreen wiper and windscreen washer (Fig. 16)

Windscreen wiper.

To operate : Move the lever downwards ; in the first position one obtains normal speed, pushing further an increased speed for exceptional use only, for very heavy rain or road spray.

Intermittence : With the windscreen wiper running normally, turn the button situated under the steering housing, to the left ; the wipers will stop after a few sweeps and then start again automatically. Turn the button more or less according to the frequency and duration required.

To stop : Push the lever upwards and the wiper arms will assume automatic parking position.

Windscreen washer.

Move the lever towards the steering wheel.

From time to time clean the windscreen wiper blades.

LAMPS, SIGNALS, WINDSCREEN WIPER, WINDSCREEN WASHER.

Switch for lighting (Fig. 17)

- Off : The lights are extinguished when the side of the knob marked with a point is in front of the driver.
- Dipped lighting : With the lever pivotted towards the steering wheel, turn the button one notch (a green warning light will show in the warning area).
- Main beam lighting : Still with the lever pivotted towards the steering wheel, turn the button to the second notch (a blue light will show).
- Side and Tail : From the positions "Main" or "Dipped", pivot the lever away from the steering wheel.
- Directional lights : With the lever in position "Main" press the centre of the button : press again to extinguish.

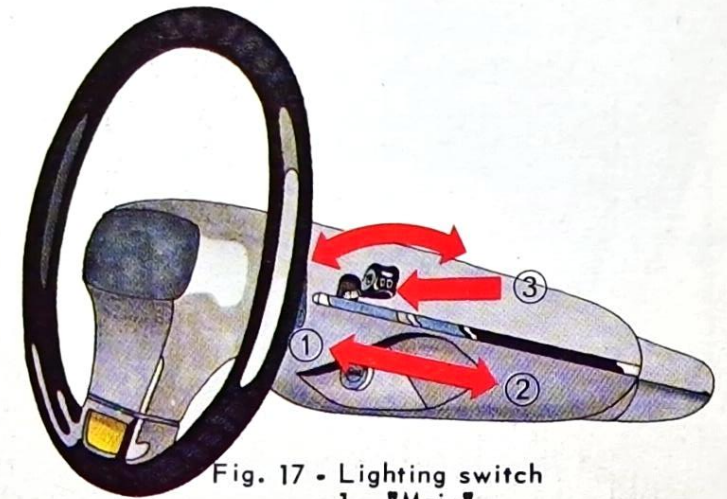

Fig. 17 - Lighting switch
 1 - "Main"
 2 - "Dipped"
 3 - Directional Long Range Lamps

Switch for Fog Lamps (Option)

- To operate : press on the switch
- To extinguish : press again on the switch and release.
- Fog lamps are automatically extinguished when "Dipped" lighting is in use.

Switch for parking lights

- To operate : press on the mark corresponding to the side required.
- To extinguish : return the rocker to the mid-position.

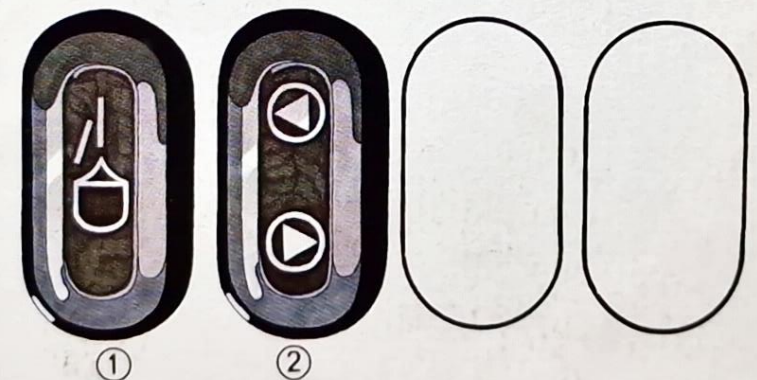

Fig. 18 - 1 - Switch for fog lamps
 2 - Switch for parking lights

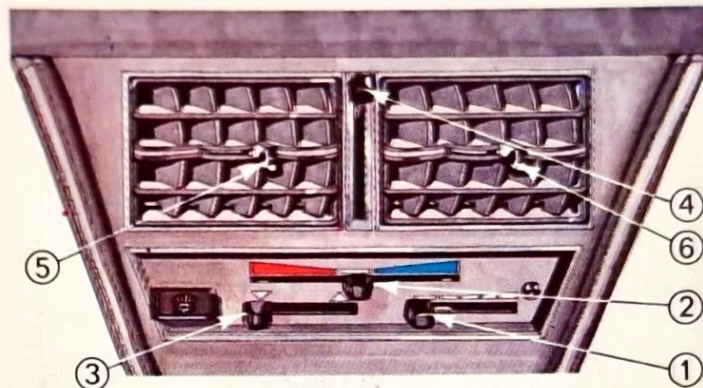

Fig. 19 - Air conditioning control

- 1 - fan control
- 2 - temperature adjustment
- 3 - distribution windscreen/floor
- 4 - central grille control
- 5 & 6 - grille direction

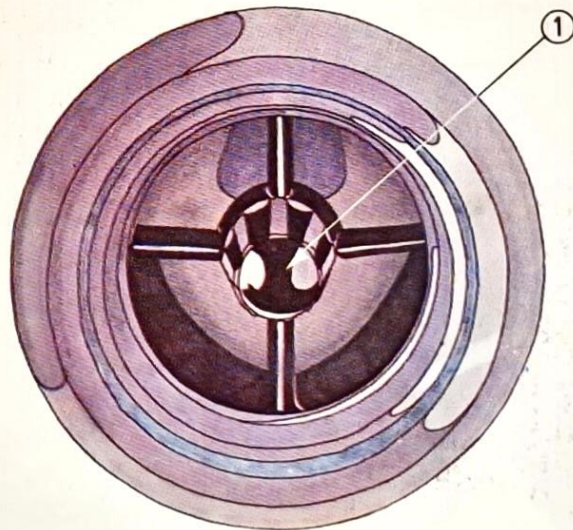

Fig. 20 - Side ventilator

- 1 - button for opening and adjusting

Switch for fan (Fig. 19 - Item 1)

To operate : move the knob towards the right (4 air streams crossing from left to right).

To stop : push fully towards the left.

Adjustment of temperature of forced air (Fig. 19 - Item 2)

In the centre : ambient air available to the central grilles and side ventilators.

To the left : hot air (maximum temperature fully to the left) distributed between windscreen and floor, ambient air available to central grilles and side ventilators.

To the right : Cars with air conditioner : cold air (minimum temperature fully to the right) available at all the forced air entries.

: Cars without air conditioner : ambient air available at all entries for forced air.

Forced air distribution between windscreen and floor (Fig. 19 - Item 3)

Fully to the right : Air directed towards the windscreen

Fully to the left : Air directed towards floor

Intermediate positions : Air is divided between windscreen and floor.

This distribution can only be obtained when the adjustment control for temperature is fully to the left or to the right. According to which position, the distributed air is :

- hot or cold (cars with air conditioner)
- hot or ambient (cars without air conditioner).

Control for central grilles (Fig. 19 - Item 4)

Closed : lever fully up.

Open : lever down (maximum output : fully down)

The air obtained may be :

- ambient or cold (cars with air conditioner)
- ambient only (cars without air conditioner).

Direct the air high or to the sides with the aid of the knobs on the centre of the grilles :

Control of side adjustable ventilators (Fig. 20)

Open : turn the button in a clockwise direction, more or less according to the output desired.

The air obtained may be :

- ambient or cold (cars with air conditioner)
- ambient only (cars without air conditioner).

Electrical heating of rear window (Fig. 21)

To operate : press the switch (a yellow warning lamp will come on in the central warning lamp cluster).

To stop : press again and release.

Rear window heating only operates when the ignition is on.

Using the forced air system

- Start up the fan, at the desired speed.

To obtain ambient air only :

- place the temperature adjusting knob in midway position.
- open, adjust and direct the central grilles and the side ventilators.

On vehicles without air conditioner it is possible to obtain also ambient air to the windscreen and to the floor by moving the temperature adjustment knob to the right.

Distribute this air between windscreen and floor.

To obtain hot air.

- move the temperature adjustment knob towards the left, more or less according to the air temperature desired.
- distribute the hot air between windscreen and floor.

It is possible to obtain at the same time ambient air for the central grilles and the side ventilators.

To obtain cold air (vehicles with air conditioner) ;

- move the temperature adjusting knob to the right, more or less according to the air temperature desired.
- distribute between windscreen and floor.

Open, adjust and direct the central grilles and the side ventilators.

To drain off the water which condenses on the walls of the air-conditioner, a hole is provided, just behind the R.H. front wheel.

When the car is stationary, a certain amount of water can collect at this point, the amount will vary according to the humidity of the air.

De-misting, de-frosting

Windscreen and side front windows ; direct the air to the windscreen.

Rear window : operate the electric heating.

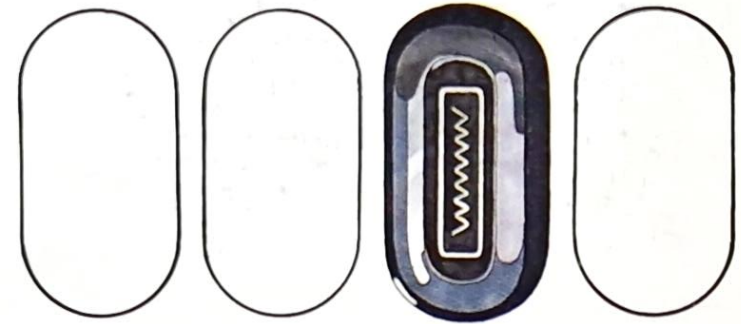

Fig. 21 - Switch for rear window heating.

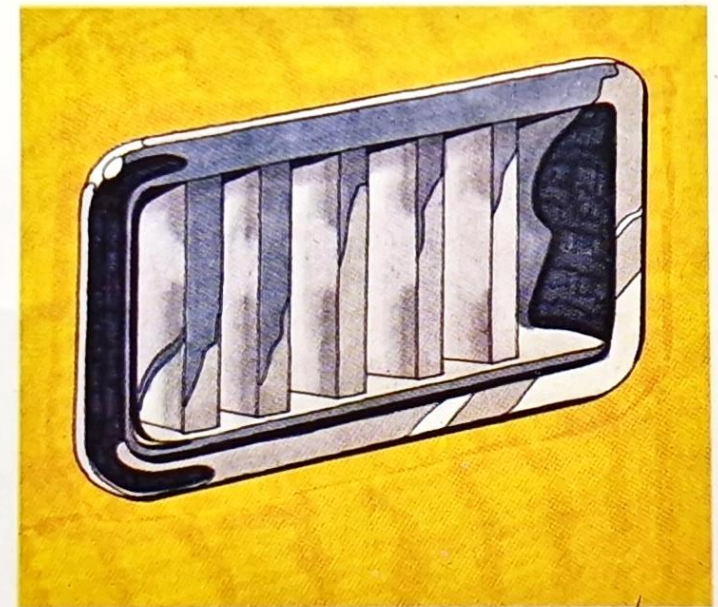
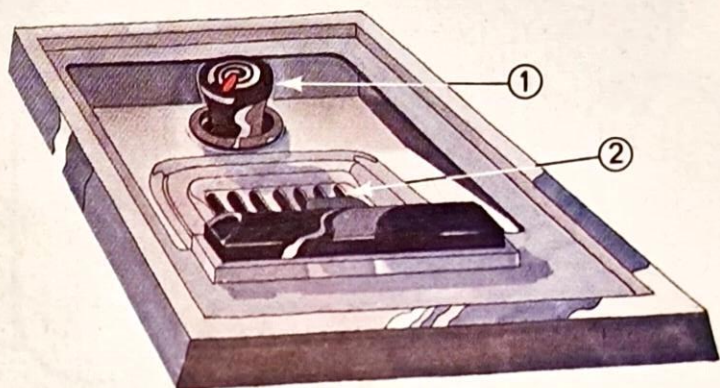

Fig. 22 - floor ventilation outlet.



Ashtray and cigar-lighter unit. (Fig. 23)

This is situated behind the gear lever and is illuminated when the exterior lighting is in action.

To open the cover, pull the knob backwards.

To use the cigar lighter, push it in and wait until it returns to its original position before taking it out.

To free the ashtray, simply lift it upwards.

Rear ashtrays

They are on the side panels.

To open them, pivot them.

To remove them, open them and then remove in a downward direction.

Sun visor

This may be turned to the side after freeing from the central support.

The sun visor for the passenger is fitted with a mirror.

Radio (Optional)

Housing for a radio set is provided to the right of the handbrake.

Three speakers arranged in the vehicle and a mixer permit listening under the best acoustic conditions.

Side Arm Rests

The side arm rest covers give access to the map pockets when lifted.

Map reading lamp

The map reading lamp and its control switch are situated in front of the passenger, under the facia panel.

Instrument panel (Fig. 24)

This is illuminated automatically when the doors are opened.

The lighting, when the doors are closed, is controlled by a switch on the dashboard, to the right-hand of the driver.

To illuminate this : press the switch.

To extinguish it : press again and release.

The position of the combined anti-theft ignition starter switch is illuminated at the same time as the interior lighting.

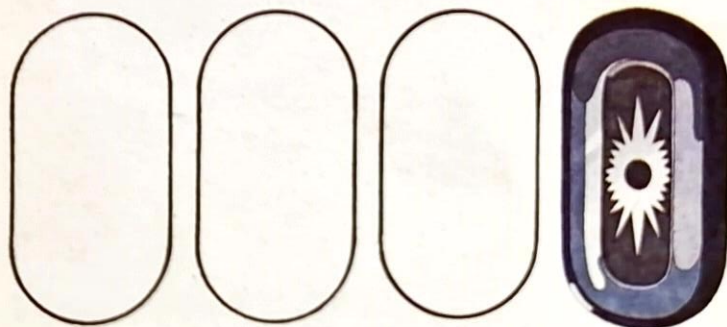

MAINTENANCE

1 Engine oil filling tube

The level should be checked from time to time between changes, and also before long runs.

It should be checked with the engine cold and the car horizontal.

The gauge is situated at 3 and carries two marks between which the level should indicate.

Oil capacity between maximum and minimum levels is 1 litre (1 3/4 pts. Imp.)

To fill up, fill until the upper line is reached, but not passed.

In summer as in winter, use TOTAL OIL "GTS 20 W 50" or, in very cold countries (North of U.S.A., Sweden) TOTAL OIL "GTS 10 W 30".

Never use additives.

2 Battery

Check the level periodically, especially in summer.

This should be above the top of the plates between 1 and 2 centimetres (3/8 to 3/4 in) in all six cells.

Top up with distilled water. Never add acid.

Never use a naked flame when checking the battery.

3 Engine oil dipstick position**4 Radiator filler cap**

Turn the cap as far as the safety notch, then press to continue turning.

If the engine is hot, stop at the first notch and allow the vapour to escape before removing.

The level should be between 2 and 3 centimetres (3/4 to 1 1/4 in) above the lower level of the filler tube.

Do not fill up a hot engine with cold water ; wait until it cools.

5 Hydraulic fluid reservoir

The level, visible through the transparent indicator, should be between the marks "Mini" and "Maxi", the checking being carried out when the car is in the maximum height position (see page 12).

IMPORTANT : To top up, use only green "LHM" Fluid distributed by TOTAL.

All other fluids are forbidden because they will rapidly destroy the hydraulic installation.

In case of emergency or if it is impossible to obtain green "LHM" fluid, see page 34.

6 Windscreen washer

Fill up with clean water to which may be added a pastille of a product such as "Stop-Clair" in any season and a solution type "Stop-Gel" in winter.

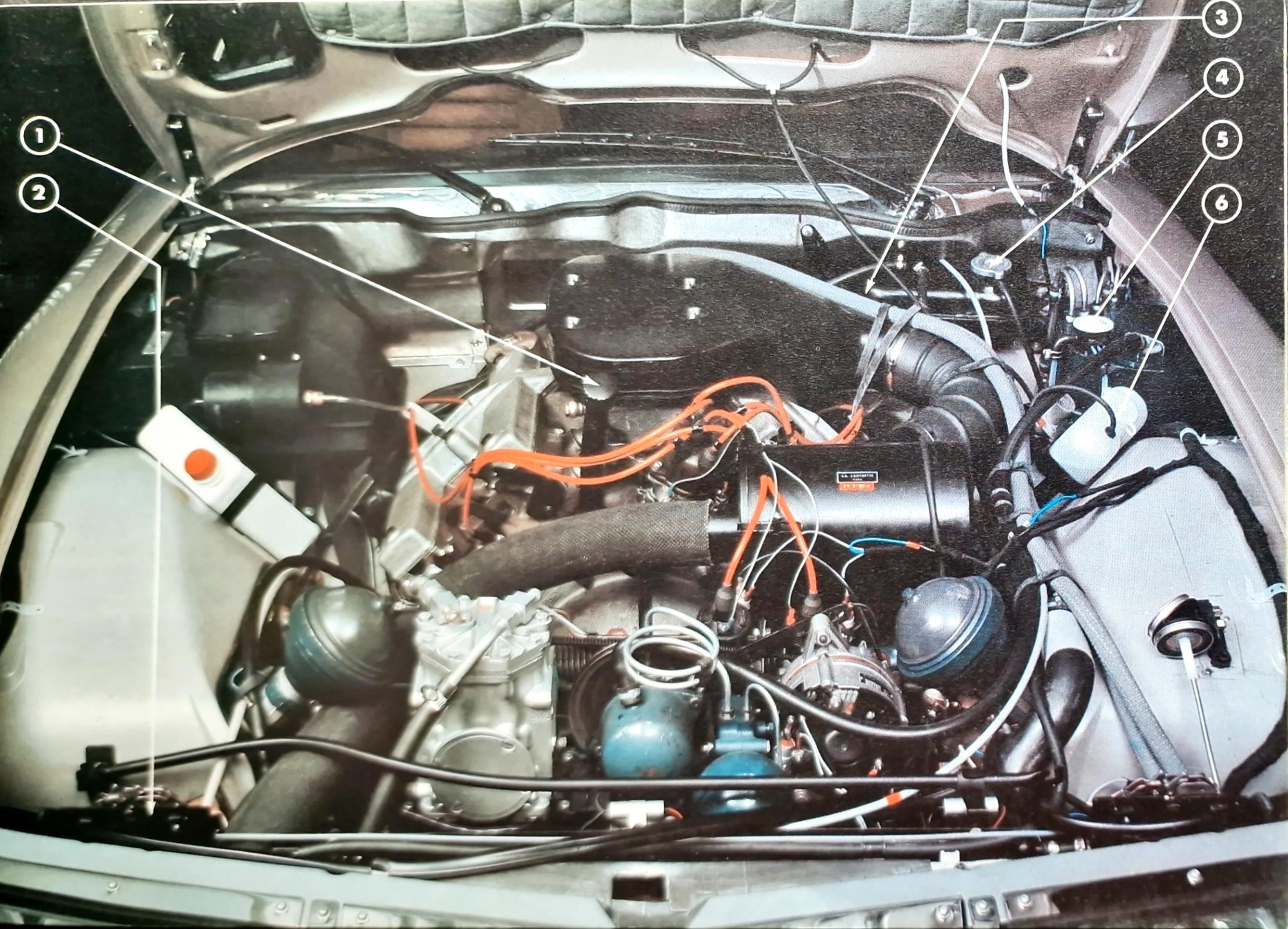

1

2

3

4

5

6

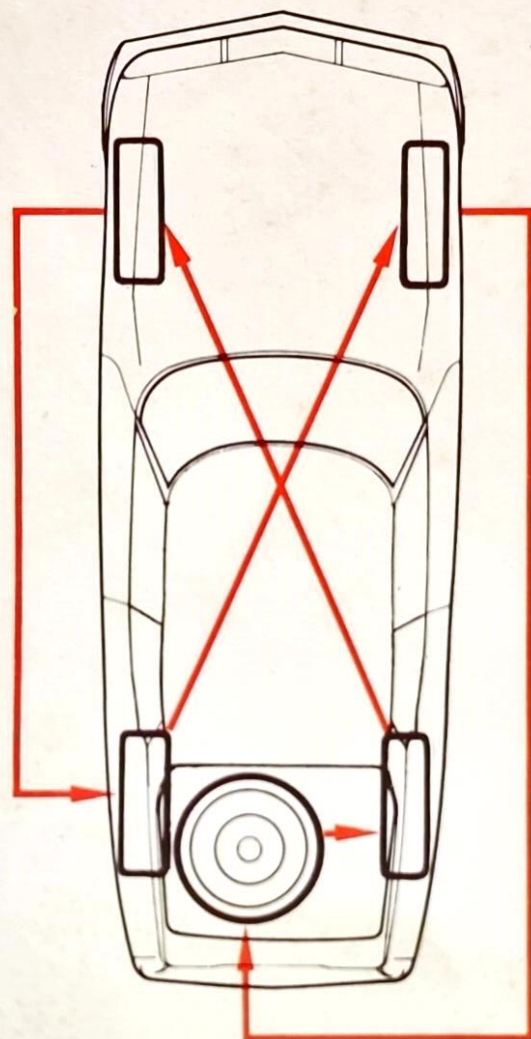

Fig. 26 - Changing round of the tyres

Periodical maintenance operations

These are indicated in the "Maintenance Guide" which accompanies this manual. We would recommend you to adhere to the frequencies indicated and to remind you that we recommend exclusively TOTAL lubricants.

All mixtures and experiments are forbidden, and in particular the use of oil additives, of any kind, as these may lead to serious trouble.

Tyres

The Michelin tyres 195/70 VR-15 X supplied with the vehicle should be inflated to:

- 2.2 bars at the front (32 psi)
- 2 bars at the rear (29 psi)
- 2.4 bars in the spare (35 psi)

Do not forget to adjust the spare wheel pressure as soon as possible after putting it in use.

It is necessary to check the pressure at least once every month and before any long journey because safety depends on this. It also has a great influence on the life of the tyres.

The checks should be carried out cold, that is to say in the morning for preference and before the tyres have been heated by running; the pressure may in fact be increased by up to 0,5 bar (7 psi) on a loaded vehicle running at high speed.

Check the wheels for balance, especially after a puncture repair.

Changing the wheels round evens out the wear on the five tyres. Thus, the wheels should be changed round sufficiently often to avoid any appreciable difference in wear between the two tyres on any one axle.

Follow the diagram here with which brings the spare wheel into the sequence. Adjust the pressures after each change.

Snow tyres

The car may be equipped with snow tyres 185-15 X M + S. It is necessary, in this case, not to exceed:

- 165 km/h (100 mph) when the tyre is not studded.
- 150 km/h (95 mph) when the tyre is studded.

The pressures are the same as those for the 195/70 VR-15 X.

Do not use tyres other than those we have listed.

Battery maintenance

Check the terminals and the leads for cleanliness. If they are sulphated, unscrew them, clean them, soak the felt insulating washers in castor oil or in neutral vaseline oil.

If the car is not in use, recharge the battery every month.

In winter, a correct charge protects against freezing. The battery charged normally (a density of 1.25 to 1.27) resists to -50°C whilst a discharged battery (density 1.07 to 1.09) may burst at -5°C .

Do not disconnect the leads from the terminals when the engine is running.

Never recharge the battery without having disconnected the leads from the two terminals.

Radiator maintenance

The cooling water contains, when it leaves the factory, a dose of TOTAL anti-freeze sufficient to protect the radiator and the cylinder block up to the temperature indicated on the label stuck on the radiator filler.

We recommend exclusively TOTAL anti-freeze.

The proportion which protects the engine up to -15°C is 3 litres (5 pts Imp) of anti-freeze and 7 litres (12 1/2 pts Imp), of water to obtain 10 litres (17 1/2 pts Imp) of cooling liquid.

TOTAL anti-freeze contains a corrosion inhibitor.

We recommend renewing the cooling liquid once every year, at the beginning of the cold season. This is a delicate operation and should be carried out by a Citroen Agent.

The bodywork should be maintained regularly, above all in winter. This maintenance should be carried out not only on the paintwork and metal embellishers, but also underneath the vehicle. Ask a Citroen Agent about this latter point.

Never clean the bodywork dry, for fear of scratching the paintwork.

Petrol, paraffin, trichlorethylene and alcohol are damaging to the paintwork as well as to the plastic parts, such as lamp covers. Never use high pressure washing.

Washing the bodywork

Although frequent washing is necessary for maintaining the paintwork, it is also important to observe the precautions given below.

Washing should never be carried out in full sun nor in a freezing temperature. It is necessary to wait until the surface is cool if the car has been exposed to the sun or if the engine bonnet, due to a long run, is still hot.

The bodywork should be thoroughly soaked with water, using either a soft sponge without rubbing, and frequently rinsing it, or using a light water jet. If a car shampoo is used, ample rinsing with water must follow.

Then rub with a piece of thoroughly clean chamois leather, rinsed frequently and squeezed out and see that no water marks are left on the paintwork.

Then, before running again, apply the brakes several times to ensure dry brake linings.

Cleaning the glass

The window glasses may be cleaned with alcohol or with special commercial products with the exception of the rear window (see page 26).

Silicone based products are not recommended.

Pivot the windscreen wiper blades to the front and clean them with a little soapy water without pressure on the edge of the lip.

Exterior metal embellishers

Wash well with soapy water or water with a light detergent, Teepol type, preceding and following this with abundant clear water rinsing.

The wheel embellishers, in particular, should be washed very often because the mud may, after a time, damage the surface and necessitate repolishing.

We recommend, in order to maintain the brilliance of the metal, the application after drying with chamois leather, of a protection product such as "ABEL polish chrome".

Tar spots on the bodywork

It is most important to remove these as soon as possible.

Do not scrape off or use petrol or rub with cloth, but employ a special tar-removing product (such as "Antigoudron ABEL").

Polishing the paintwork

Polishing is not recommended for metallic paints because of the risk of sheering appearing.

For non-metallic paint finishes, on the other hand, it is a good thing to polish after the winter.

The bodywork must be absolutely clean and dry.

Use only those products with the faintest trace of abrasive, such as cream polish (example "LAVABEL") and follow the instructions of the maker.

Light damage to paintwork

Shallow scratches or light damage to the paintwork may be made good at little cost, without the necessity of large scale work, using the "SOUDEE SPRAY" aerosols which contain retouching paints, air drying, which we have checked for tint and quality.

These containers, sold commercially, exist in all Citroen tints. Their use is very simple and is indicated on the packing.

Point reference figures on a plaque on the car (see fig. 27) situated under the bonnet, on the right-hand front side member, below the chassis number plate.



Fig. 27 - Reference for paint colour.

Cleaning the trimming

Use only non caustic soaps, toilet type.

Trimming in fabric :

These may be brushed or, preferably, suction cleaned.

If there is much general dirt, use commercial "dry foam" after carefully removing all traces of dust.

Trimming in leather (optional)

This should be cleaned with a cloth or sponge, dipped in tepid soapy water, well squeezed, and then rubbed with a soft cloth until it shines. Do not use cream which may stain.

Trimming in leathercloth

Clean with a product of the "SPIC" type or with a little soapy water, well rinsed and then rubbed with a dry cloth.

We do not advise products sold to make these parts shine.

Isolated marks on the trimming

Marks on the fabric, leather or leathercloth may be cleaned with soapy water or water with a little TEEPOL detergent.

If these do not remove them, use alcohol at 90° (commercial methylated spirit) or lead-free petrol.

Use squeezed out pads and rub the marks lightly.

Solvents such as acetone, trichorethylene etc. are not recommended.

There are complex cleaners containing absorbent materials and which, used with care, have the advantage of not leaving rings (example "K2R").

Instrument board surround

Use either soapy water or a commercial diluent, but nothing else.

Rear window

The interior of the rear window should only be cleaned with soapy water to avoid risking the destruction of the printed circuit for the electric heating.

REPLACEMENTS

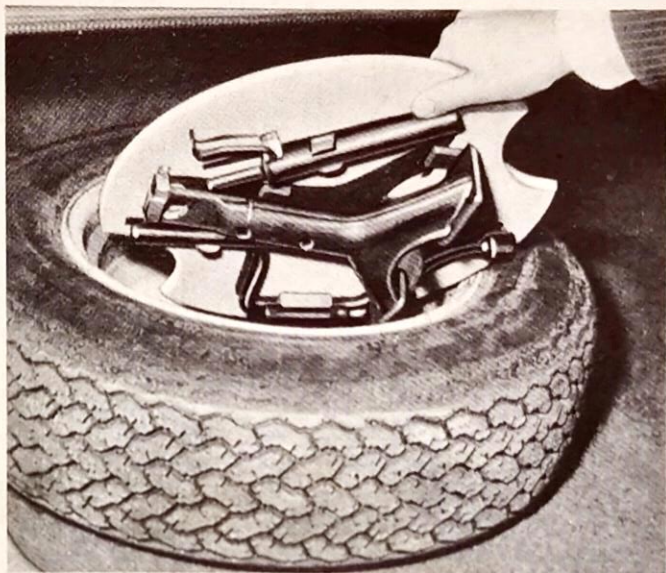

Fig. 28 - tools for removing the wheels



Fig. 29 - siting the jack

Tool kit

This is stored in the boot and is fixed on a plate on the spare wheel, under the cover (see fig. 28).

Removal of a wheel

Apply the handbrake fully.

Start up the engine and allow to run at idling speed.

Place the adjusting lever for the ground clearance in the extreme rear notch (maximum height).

Remove the wheel embellisher : unscrew the central screw and introduce the curved end of the bar under the edge to serve as a lever. Loosen, without removing, the five wheel nuts, with the brace.

When the vehicle is at maximum height, engage the stay in the slot under the front door and engage the straight end of jacking peg in the hole nearest the base (see fig. 29).

Rear wheels only :

Remove the moveable flap of the wheelarch by unscrewing with the brace the screw situated at the front end (see fig. 30).

Raise the rod near the spare wheel and engage the notch on the left of the boot cover (see fig. 31).

Place the adjusting lever for the ground clearance in the extreme front notch (minimum height) and wait until the wheels rise.

Continue unscrewing the five wheel nuts and then remove the wheel.

REPLACING A WHEEL

Replacing

Engage the wheel on the studs.

Screw on the five nuts without tightening them.

Place the adjusting lever for the ground clearance in the extreme rear notch (maximum height).

Remove the jacking stay.

Fully tighten the five wheel nuts.

Rear wheels only :

Replace the moveable wheelarch panel.

Unhook the rear rod.

Replace the wheel' embellisher taking care that the valve hole is correctly positioned.

Replace the adjusting lever for the ground clearance in its initial position (reminder : the normal running position is marked by a white line).

Check and adjust the tyre pressure of the new wheel put into service to 2.2 bars (32 psi) at the front or 2 bars (29 psi) at the rear.

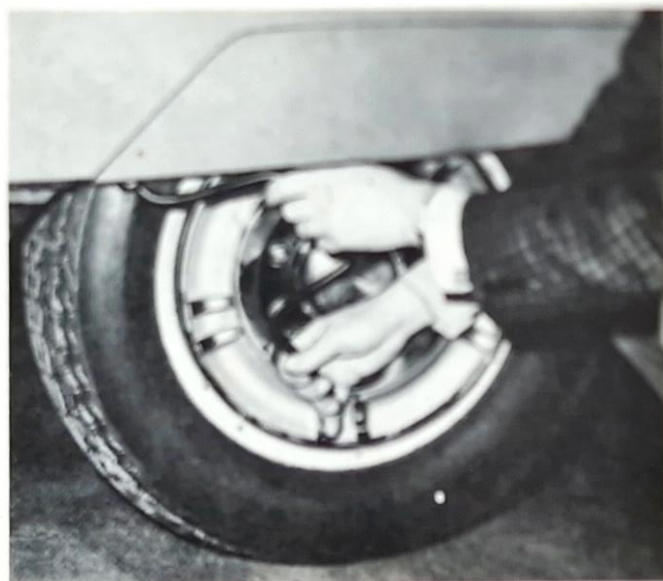

Fig. 30 - Removing the moveable panel



Fig. 31 - Inserting the locking pin on the rear height adjustor

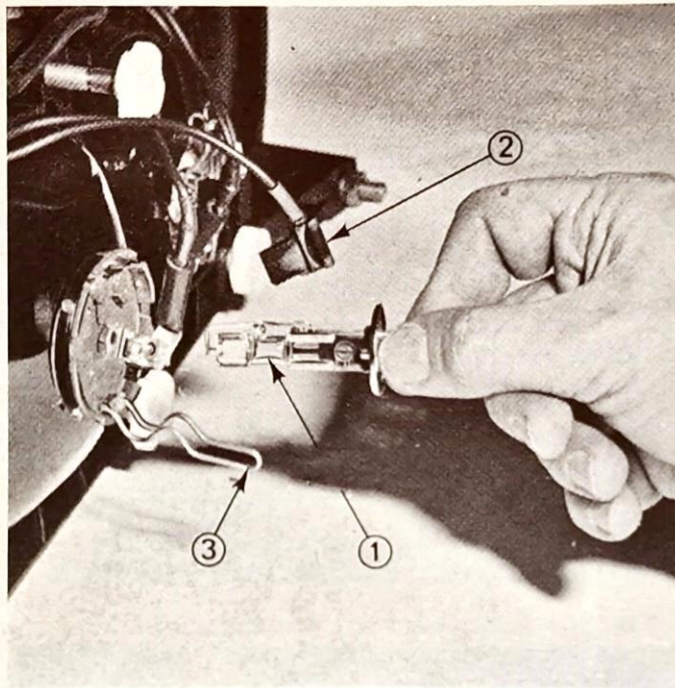

Fig. 32 - Removing a Q.I. bulb
 1 - Q.I. bulb
 2 - Electrical lead
 3 - Retaining springs

Fixed headlamps, main and dipped : Philips bulbs or Norma Q.I. type H1 - 12V

This operation to be carried out only with headlamps extinguished.

Remove the lead from the bulb.

Release the retaining springs by pressing on the ends and freeing them from the slots.

Take care not to touch the new bulb with the fingers. If this is done inadvertently, take another bulb or clean that which has been touched with a little soapy water and dry with a non-fluffy cloth.

Insert the bulb in the headlamp.

Clip the retaining springs in position.

Fit the lead to the bulb.

Directional headlamps : Philips bulbs or Norma Q.I. type H1 - 12V.

Left-hand headlamp :

Proceed as in the case of fixed headlamps

Right-hand headlamp ;

Remove the protection glass from the numberplate (7 screws to loosen) then pivot the headlamp outwards by pushing it with the hand to obtain access to the rear of the headlamp (fig. 33) .

Fog lamps (optional) Philips bulbs or Norma Q.I. H1 - 12V

Remove the 2 screws holding the lamp assembly.

Pull on the bulb support to free it.

Do not touch the new bulb with the fingers. If this is done inadvertently, take another bulb or clean that which has been touched with a little soapy water and dry with a non-fluffy cloth.

Side and Tail lamps : Bulbs 12V, 5W type R 19/5.

Remove the transparent cover (front lamp : 3 screws to loosen, rear lamp 2 screws)

Direction indicators : Bulbs 12V, 21W type P25/1

Remove the transparent cover (front lamp 3 screws to loosen, rear lamp 2 screws)

Reversing light : Bulbs 12V, 21W type P25/1

Remove the transparent cover (2 screws to loosen).

REPLACING A BULB

Stop lamps : Bulbs 12V, 21W type P25/1

Remove the transparent cover (2 screws to loosen)

Numberplate lamp : Bulbs 12V, 5W type R19/5

Open the boot lid.

Pivot the felt protective trim, pulling on the four press studs

Loosen the two knurled knobs situated in the cavities, holding the light housing meanwhile to prevent it falling.

Change the bulb and replace the housing, then the trim.

Interior lamp : Festoon bulb 12V, 7W, length 38 mm (1 1/2 in).

Pivot the housing by means of the slot at the rear then free from the front.

To replace, engage the studs at the front then push at the rear.

Ashtray lamp : Festoon bulb, 12V, 4W, length 38 mm (1 1/2 in).

Free the ashtray - cigar lighter unit, by pulling on the edges, then lift out the light unit by pinching it.

Map reading lamp : Festoon bulb, 12V, 7W, length 38 mm (1 1/2 in).

The bulb is situated under the rubber padding of the instrument panel to the right of the switch.

Glovebox : Bulb 12V, 2W type T8/2.

Lift out the white container by pulling downwards and lightly towards the left, to free it.

Ignition key light : Bulb 12V, 2W, type T8/2.

Remove the upper part of the steering housing after having pulled towards you the 2 embellishers situated on the sides.

Light under bonnet : Bulb 12V, 10W type R19/10

Rear boot : Bulb 12V, 10W type R19/10

The bulb is to the right of the boot, under the bootlid hinge. Unhook the plastic housing.

Air conditioning control marks

The bulb replacement should be carried out by a Citroen Agent.

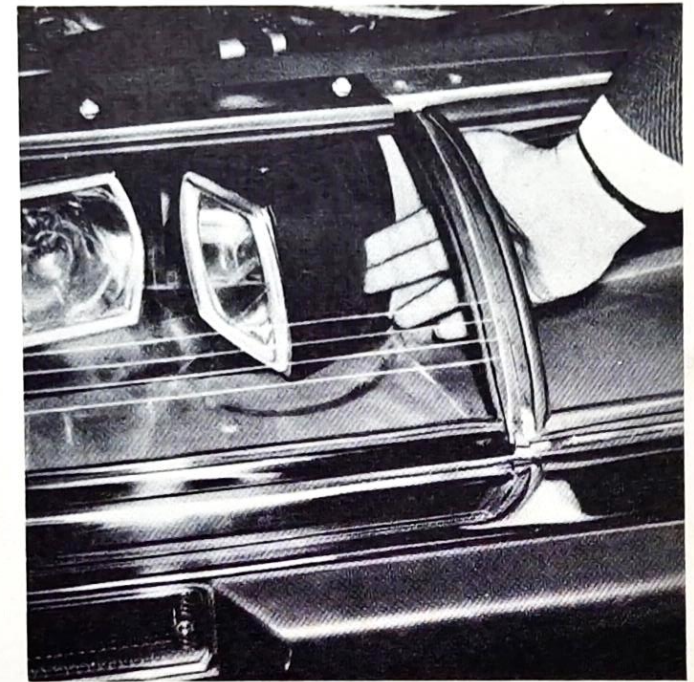

Fig. 33 - Pivoting the directional headlamp by hand.

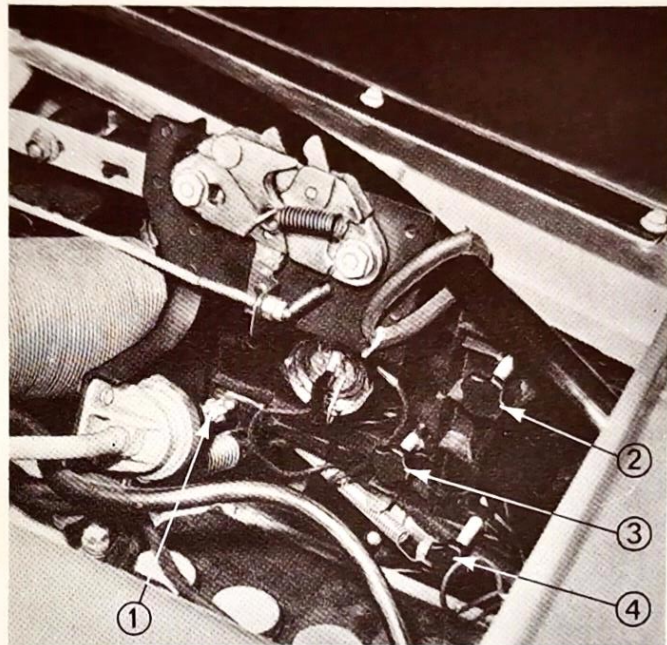

Fig. 34 - 1 - Adjustment of the headlamp assembly
2, 3, 4 - Adjusting screws for headlamps main and dip.

These adjustments can only be carried out effectively in a workshop equipped with the necessary checking devices.

Headlamp assembly (Fig. 34 - Item 1)

- Adjustment for height.

Turn the white plastic sleeve in the front right-hand corner of the engine compartment, near the battery.

Clockwise direction : moves the assembly upwards.

Directional headlamps

a) Lateral adjustment.

Turn a plastic sleeve situated under the headlamp housing. These sleeves are not visible but it is sufficient to slide the hand under the housings to reach them.

Turn them in one direction or the other according to the beam movement required.

b) Adjustment for height.

Insert a screwdriver in the hole situated in the front of the screw, in the lower part of the housing, and turn it.

Clockwise moves the unit upwards.

Headlamps, "Main" (Fig. 34)

a) Lateral adjustment

Turn the upper screw.

Clockwise : moves the beam towards the centre of the vehicle.

b) Adjustment in height.

Turn the lower screw.

Clockwise : moves the beam upwards.

Headlamps, "dipped" (Fig. 34)

a) Lateral adjustment

Adjust both screws, upper and lower.

Then carry out the adjustment in height.

b) Adjustment in height.

Turn the lower screw.

Clockwise direction : moves the beam upwards.

It is obviously necessary, before replacing a blown fuse, to determine the cause and to have this remedied.

The 12 fuses protecting the circuit (9 fuses of 16 amps and 3 of ten amps) are inside the two housings situated under the bonnet, in the centre of the bulkhead, behind the radiator filler cap.

Remove the relevant housing cover by pulling it off and renew the fuse with one of the same amperage.

List of fuses (from the centre of the vehicle outwards) and equipment protected :

1 - Blue marking (16 A)

- Warning lamp for handbrake
- Direction indicators
- Rear window heating
- Reversing lamps
- Interior lighting
- Boot lamp

- Light under bonnet
- Light in glovebox
- Map reading lamp
- Stop lamps
- Electric clock
- Radio receiver (optional)
- Accessory terminals

6 - Mauve marking (10 A)

- Numberplate lamp
- Warning light for side lamps
- Ashtray lamp
- Instrument board lighting
- Air conditioning light (optional)

2 - Yellow marking (16 A)

- Cigar lighter
- Petrol gauge
- Water thermometer
- Oil temperature gauge
- Brake wear warning lamp
- Hydraulic pressure warning lamp
- Engine oil pressure warning lamp
- Check for red warning lamps
- Windscreen wiper and windscreen washer

3 - White marking (16 A)

- Directional headlamps

4 - Green marking (10 A)

- Sidelamp, right-hand
- Stoplamp, right-hand

7 & 8 - Blue and yellow marking (16 A)

- "Dipped" headlamps

9 & 10 - White and green marking (16A)

- "Main" headlamps

5 - Red marking (10 A)

- Sidelamp, left-hand
- Stoplamp, left-hand

11 & 12 - Red and mauve markings (16A)

- Fog lamps

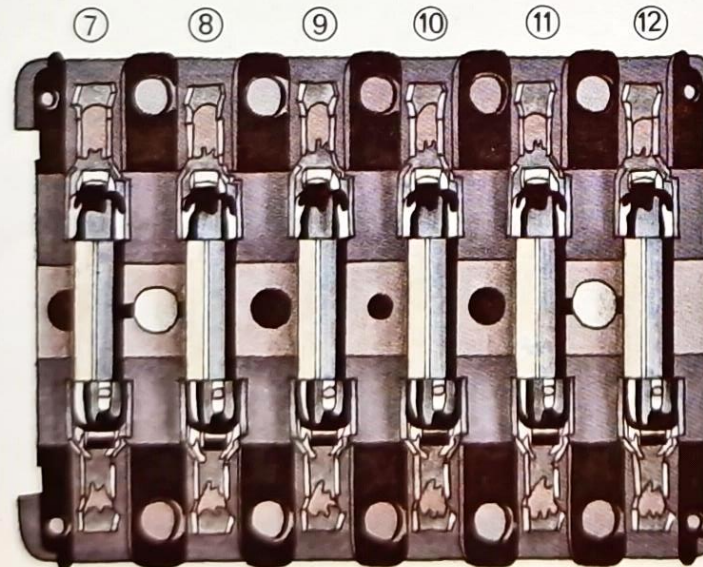
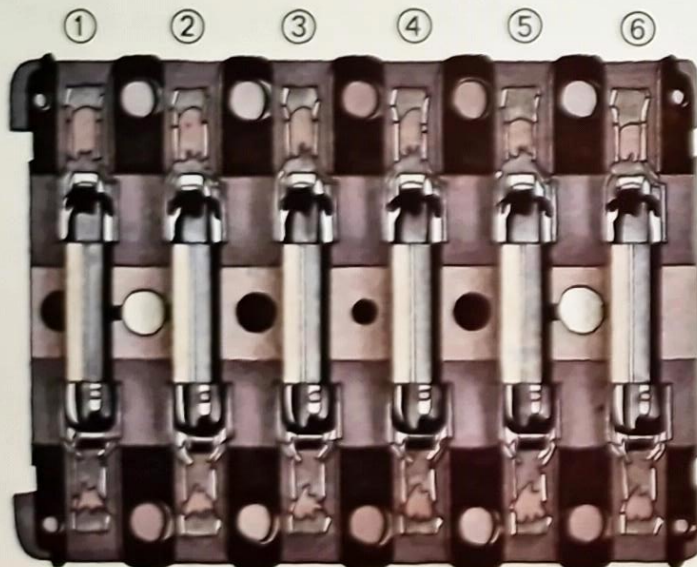

Fig. 35 - Fuse box

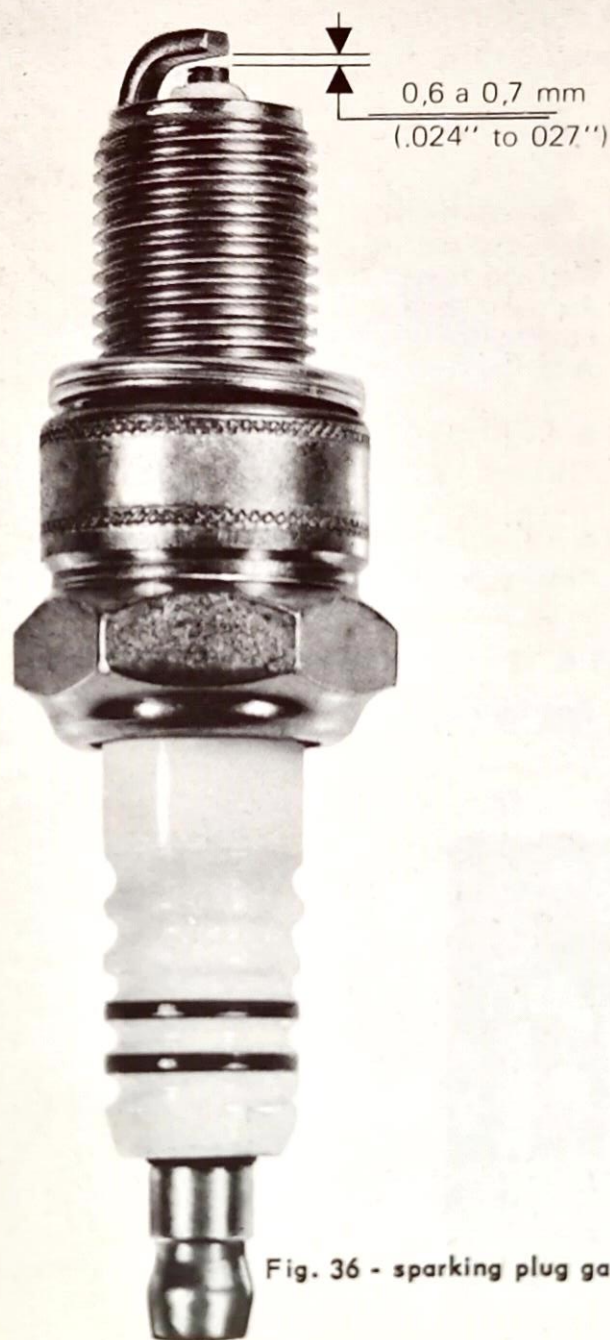

Fig. 36 - sparking plug gap.

Replacing a battery

Battery reference : 12V 300/70 AH

Place the car in maximum height position either with the aid of the engine (see page 12) or with the aid of a jack.

Move steering wheel to full left-hand lock giving light pulls to and fro on the steering wheel towards maximum lock in order to release the pressure reserve which pulls the wheels back to straight line position.

Disconnect the battery and unscrew the two tie-rods securing it. Remove, via the wheelarch the battery access panel.

Pivot the battery and lift it out with surround and lower seating. Note the position of the terminals before inserting the battery.

Replacing a sparking plug

Plug reference : BOSCH W 200 T 30

Plug gap : 0.6 to 0,7 mm (0,024 in to 0,029 in).

Replace by screwing in as far as possible by hand. Finish with spanner.

Replacing in emergency green "LHM" hydraulic fluid.

In a case of emergency, it is possible to use instead of the green "LHM" hydraulic fluid :

- either fluid engine oil SAE 10 or SAE 20
- or hydraulic fluid for convertors, FLUID A TYPE A.

It is necessary to have the reservoir drained as soon as possible and refilled with green "LHM" hydraulic fluid.

To drain the reservoir :

- place the vehicle in low position and open the bleed screw on the pressure regulator
- loosen the lower transparent level clip and allow the liquid in the reservoir to drain out.

Towing the car

By the front : Attach a cable to the lower right and left-hand wheel arms and protect the under part of the closing panel by inserting a piece of wood and stout padding.

Then raise the vehicle.

From the rear : Use the two hooks under the bumper.

GENERAL INFORMATION

Coupe Grand Tourisme

Front wheel drive

Number of seats : 4

Fiscal rating : 15 h.p.

Maximum speed : 220 km/h approx. (135 m.p.h.)

Starting on incline with

towing load of 1800 kg

(3968 lbs) : 11 % (1 in 9)

Speed at 1000 r.p.m.

1st gear : 9.4 KMH (5.8 m.p.h.) 4th gear : 28.4 KMH (17.7 m.p.h.)

2nd gear : 14.2 KMH (8.8 m.p.h.) 5th gear : 36.3 KMH (22.6 m.p.h.)

3rd gear : 20.8 KMH (12.9 m.p.h.) Reverse : 8.6 KMH (5.3 m.p.h.)

Weights

Weight, in running order : 1 450 kg (3 197 lbs)

- at the front : 900 kg (1 984 lbs)

- at the rear : 550 kg (1 213 lbs)

Total laden weight, : 1 800 kg (3 968 lbs)

- at the front : 1 040 kg (2 293 lbs)

- at the rear : 800 kg (1 764 lbs)

Maximum towing load :

- without overrun brake : 500 kg (1 102 lbs)

- with overrun brake : 1 800 kg (3 968 lbs)

Overall measurements

Length overall : 4.89 m (16 Ft. 5/8 in)

Width overall : 1.83 m (6 Ft. 1/4 in)

Steering diameter

- between walls : 11.5 m approx. (37 Ft. 9 ins)

- between kerbs : 10.5 m approx. (34 Ft. 6 ins)

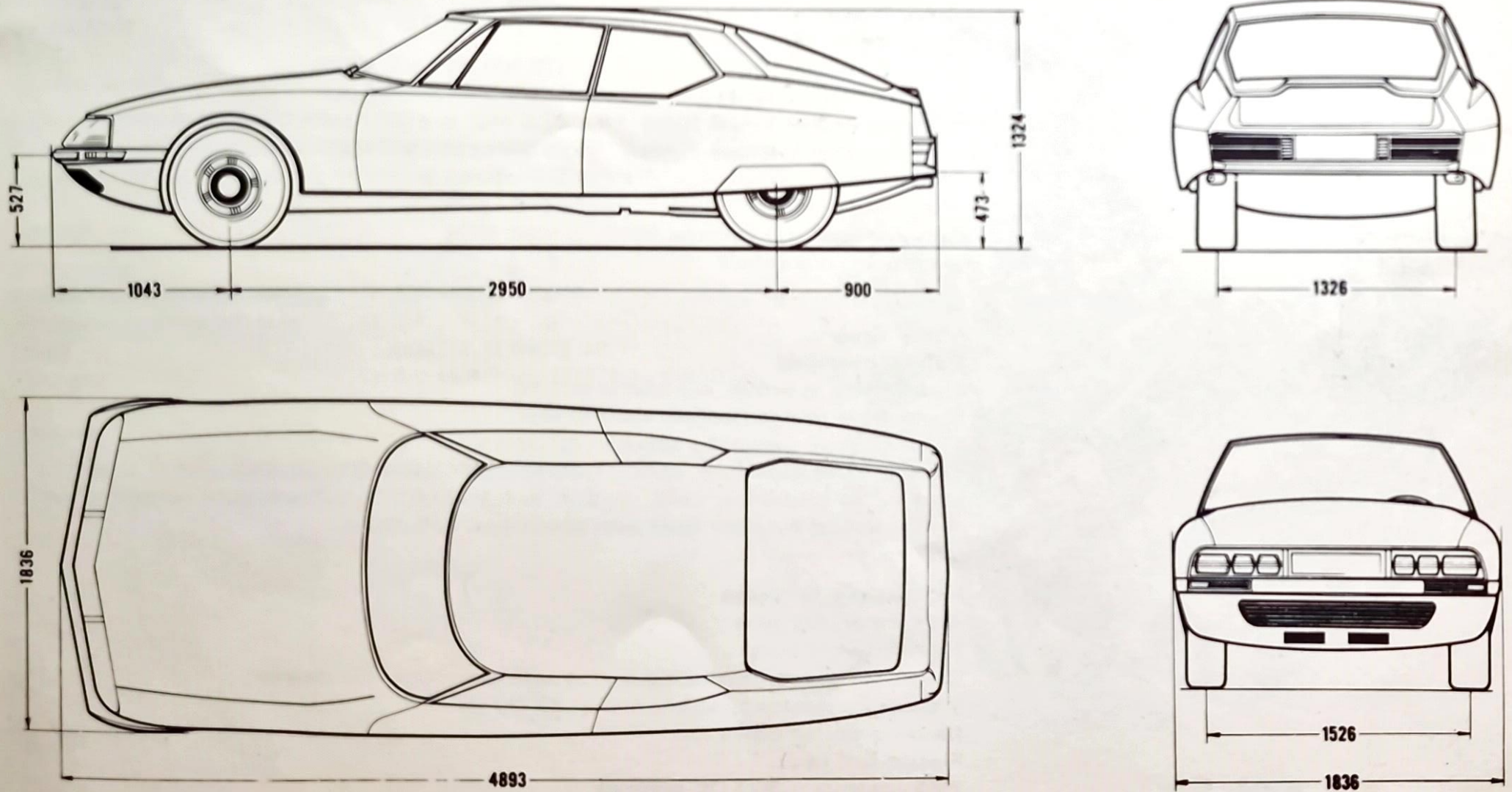

Fig. 37 - overall measurements

General

Symbol	: Maserati type C114/1
Number of cylinders	: 6, 90° Vee
Bore	: 87 mm
Stroke	: 75 mm
Cubic capacity	: (2670 cc)
Compression ratio	: 9 : 1
Maximum output (DIN)	: 170 h.p. at 5500 r.p.m.
Maximum output (SAE)	: 180 h.p. at 6250 r.p.m.
Maximum engine torque (DIN)	: 23.5 mkg at 4000 r.p.m. (170 ft. lbs)
Maximum engine torque (SAE)	: 23.8 mkg at 4000 r.p.m. (171.14 ft. lbs)
Idling speed	: 900 r.p.m.
Maximum speed	: 6500 r.p.m.
Cylinder head and cylinder block in light alloy	
4 - bearing crankshaft	

Valve Gear

Valves overhead	
4 camshafts in heads, adjustable setting	
Chain drive to intermediate shaft at rear	
Chain drive to camshafts between cylinders	
Exhaust valve clearance, cold	: 0.50 to 0.55 (0.020 to 0.022 ins)
Inlet valve clearance, cold	: 0.32 to 0.35 (0.012 to 0.014 ins)
Hemispherical cylinder head with directional turbulence.	

Fuel supply to engine

Air cleaner, dry type	
Electric petrol pump	
Crankcase gas re-circulating device with centrifugal oil cleaner	
3 Weber carburettors, double choke, 42 DC NF	
Hand-controlled choke	
Plastic fuel tank	
Tank capacity	: 90 l (20 gallons)

Lubrication

Under pressure by gear pump and pressure control valve.
 Oil cooler in light alloy :
 Maximum oil pressure : 4.5 to 5.5 bars 4 000 r.p.m.
 Minimum oil pressure : 1.5 bars at 1 000 r.p.m.
 Oil capacity : 7 l. (12 1/4 pts Imp)

Cooling system

Radiator with cross-flow matrix
 2 electrically driven fans, thermostatically controlled
 Capacity : 13 l. (23 pts Imp.) including the heating system.

Ignition

Firing order : 1 - 6 - 2 - 5 - 3 - 4
 Stroboscopic advance setting : 32° at 2 000 r.p.m.
 Automatic ignition advance : 30°
 Plugs : BOSCH W 200 T 30
 Plug gap : 0.6 to 0.7 mm (0,024 to 0,028 in)

Exhaust

2 silencers, 1 longitudinal, 1 transverse
 2 rear expansion chambers.

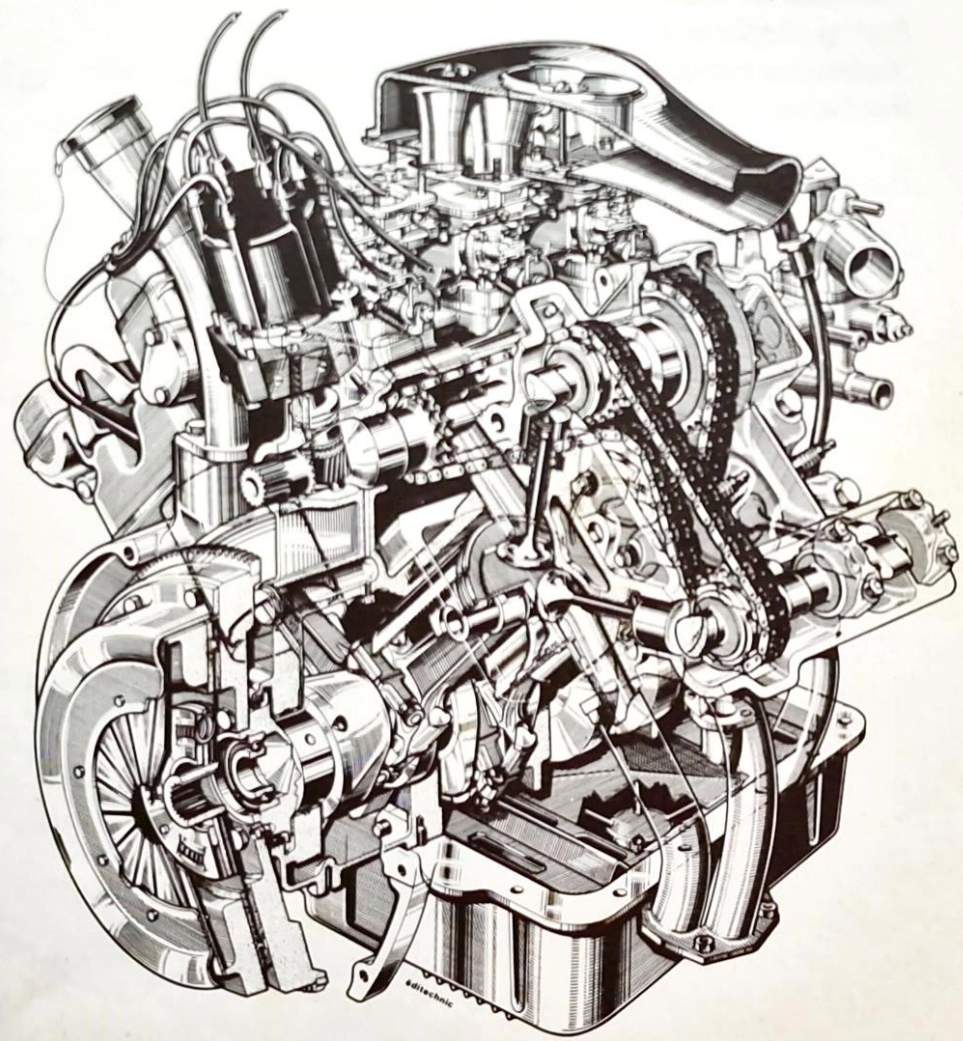

Fig. 38 - Engine

Clutch

Single dry disc.

Diameter of disc : 228 mm (9 ins)

Spring diaphragm

Hydraulic control by master cylinder and slave cylinder

Mechanical assistance by spring

Gearbox, Drive and Differential

Compact assembly en bloc with engine

Mechanical control through lever on floor

5 speed, synchronised and reverse

Gear ratios :

1st speed : 2.923 : 1 (0.342)

2nd : 1.9411 : 1 (0.515)

3rd : 1.3214 : 1 (0.756)

Spiral bevel gear drive, Gleason

Ratio : 4,375 : 1 (8 × 35) (0.228)

4th : 0,9696 : 1 (1.031)

5th : 0,7567 : 1 (1.321)

Reverse : 3,1538 : 1 (0.317)

Transmission joints

Double constant-velocity Hooks-joint at wheel end.

Tri-axe sliding joint at gearbox end.

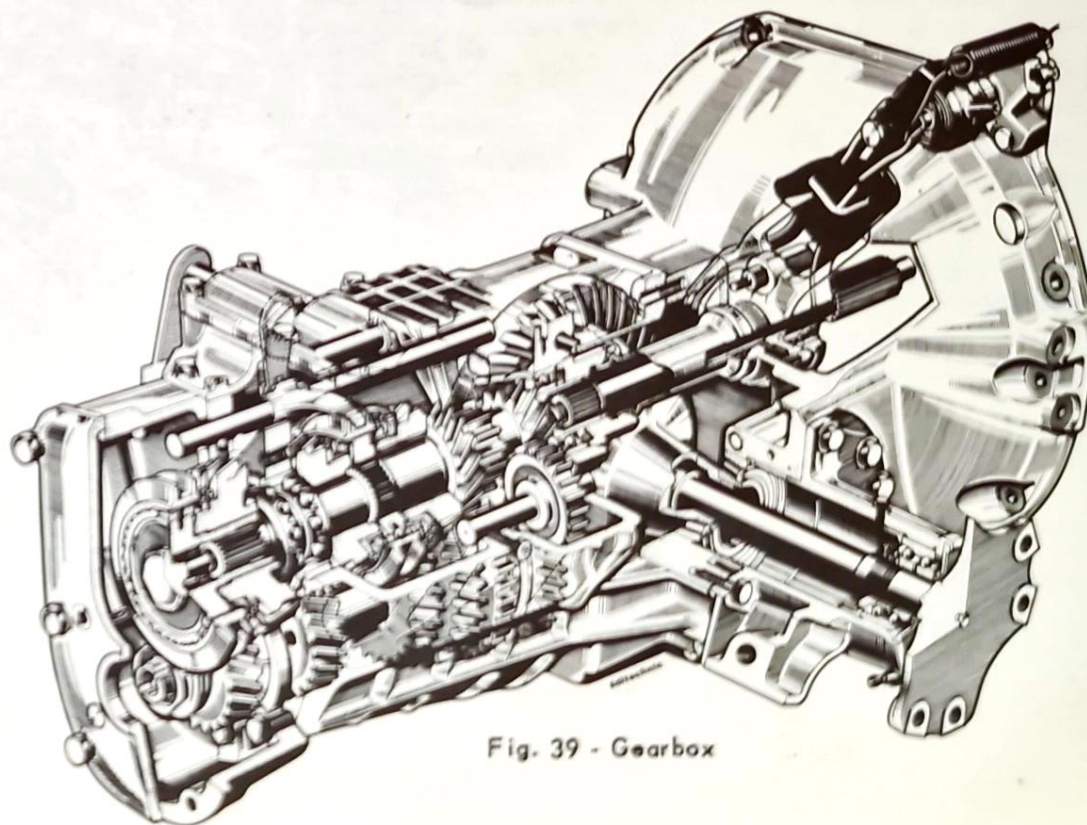

Fig. 39 - Gearbox

TECHNICAL CHARACTERISTICS : HYDRAULIC INSTALLATION

High pressure pump, 7 pistons

Drive by flector shaft coupled to engine intermediate shaft.

Large hydraulic fluid tank and hydropneumatic accumulator equipped with regulator and pressure distributor.

Tank capacity : 5,400 l. (9 1/2 pts Imp.)

Hydropneumatic accumulator capacity : 0,380 l. (380 cc)

Maximum pressure in accumulator : 175 bars.

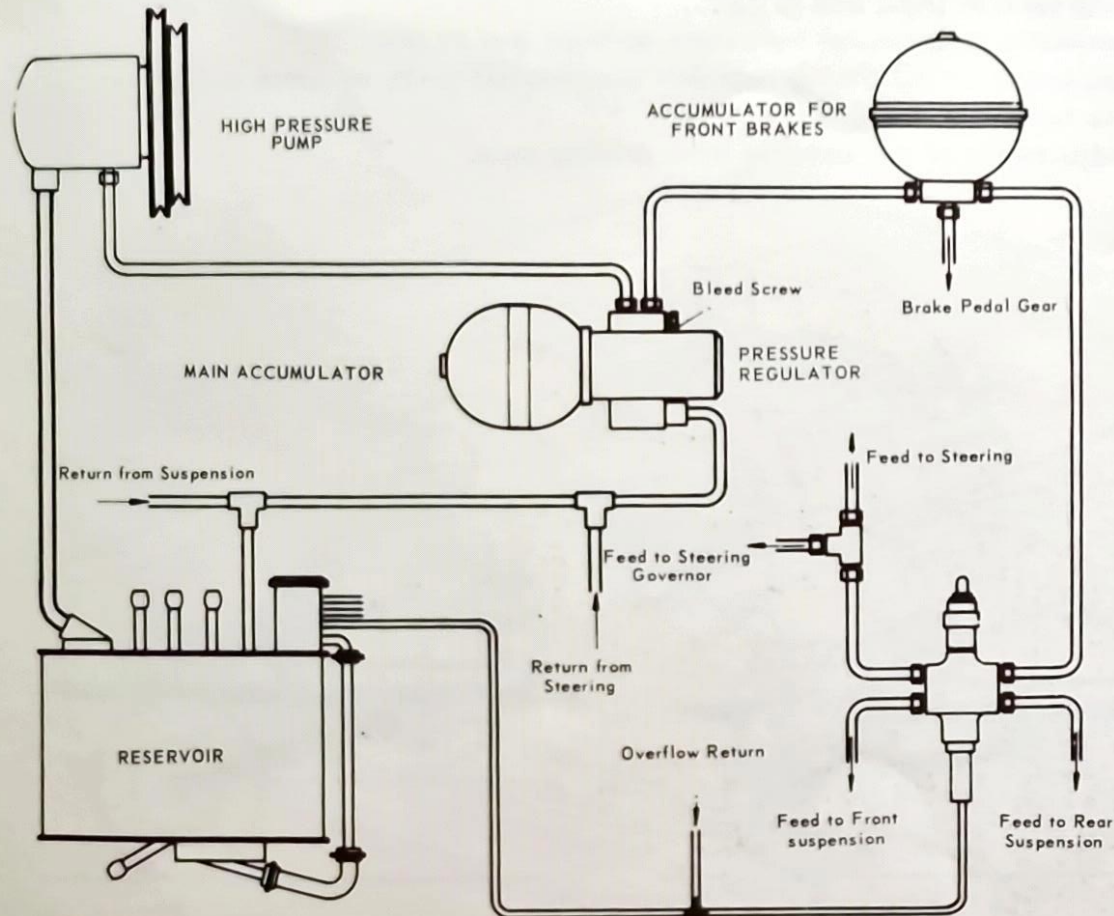

Independent wheels at front and rear.

Suspension : - transverse equal length link-arms at front, trailing single arm at rear

Stabilising bars at front and at rear.

Hydropneumatic suspension cylinders at front and at rear.

Automatic pressure-balancing between suspension units on same axle.

Automatic height correctors.

Height adjustment of the vehicle from driving seat.

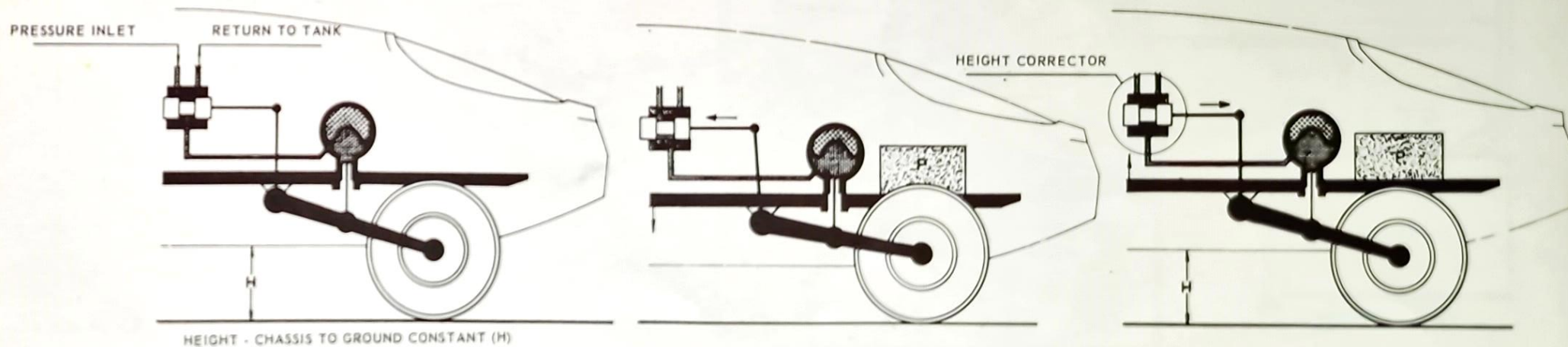

Fig. 41 - Height corrector

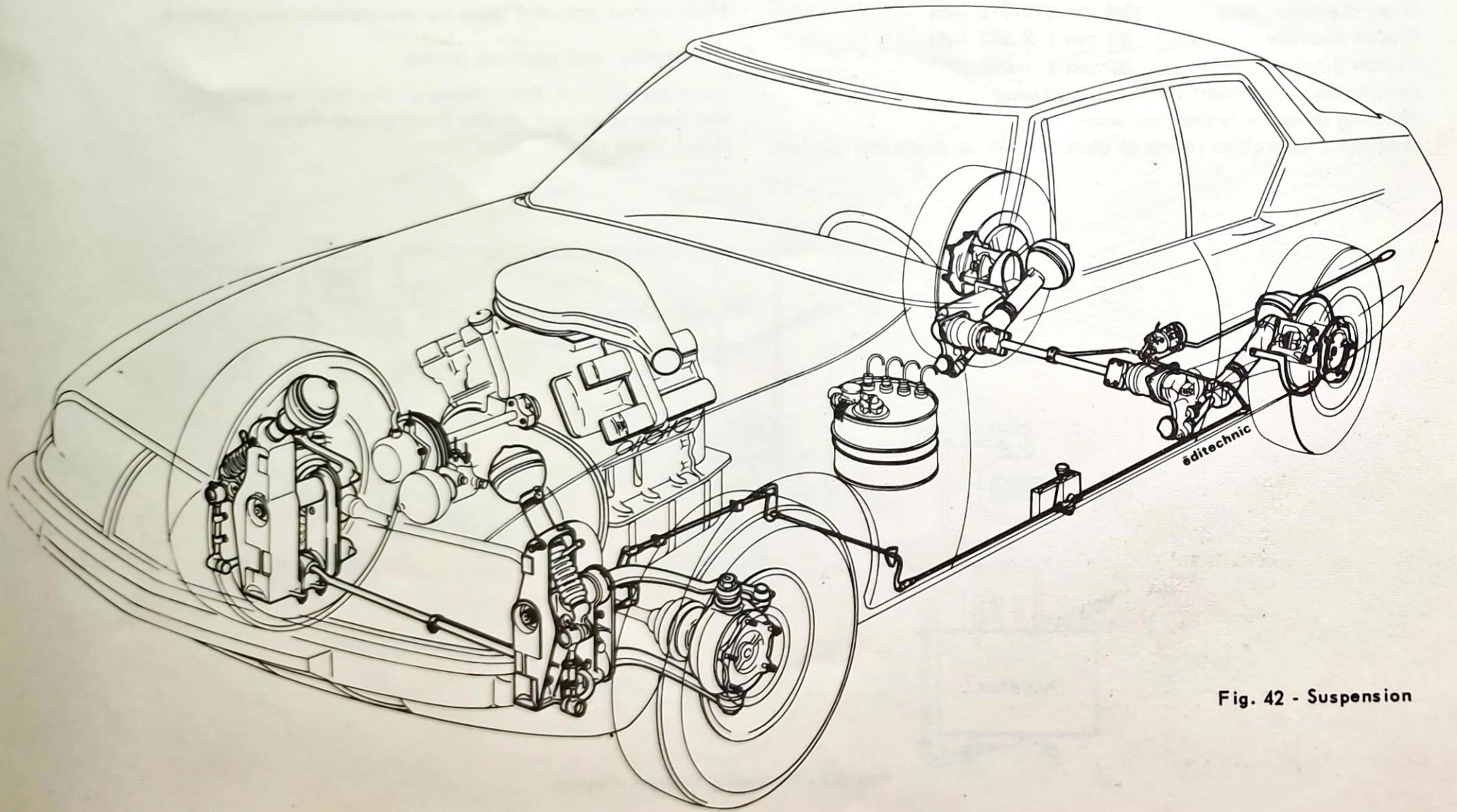

Fig. 42 - Suspension

Main brake

Disc-brakes on the four wheels

Calipers with opposed pistons

Disc diameter, front : 300 mm (11.811 ins)

Disc diameter, rear : 256 mm (10.079 ins)

Piston diameter, front : 60 mm (2.362 ins)

Piston diameter, rear : 32 mm (1.260 ins)

Automatic adjustment for brake pad wear.

Warning lamp for brake pad wear.

Hydraulic operation (mineral based fluid) with double circuit.

Constant efficiency ensured by pressure from pressure-reserve device.

Braking distributed between the axles and limited on rear axle automatically as a function of the suspension pressure distribution.

Illuminated warning lamp for minimum brake pressure.

Emergency and parking brake

Separate linings from those of the main brake.

Mechanical action on the front wheel discs.

Hand lever control from floor.

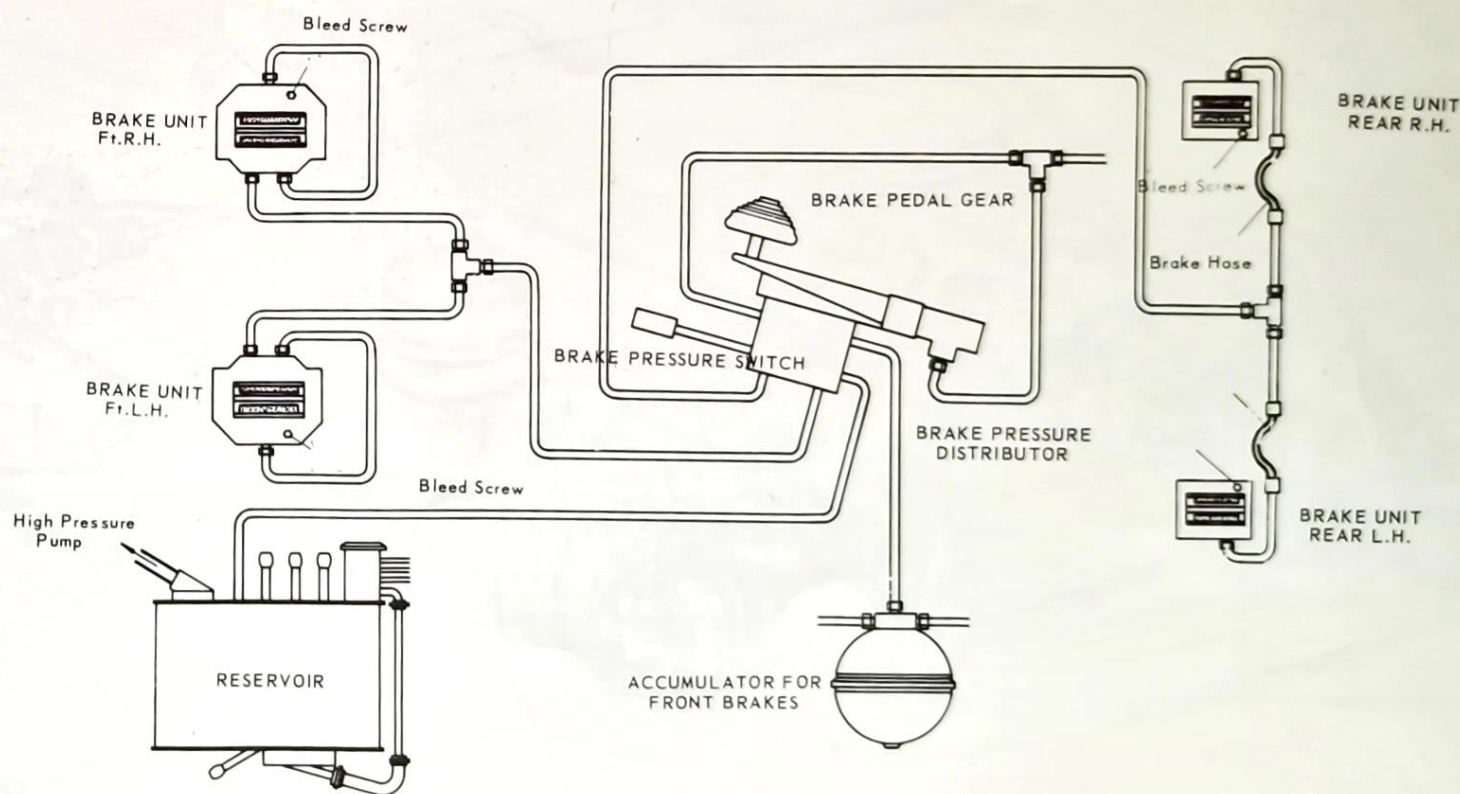

Fig. 43 - Hydraulic braking diagram

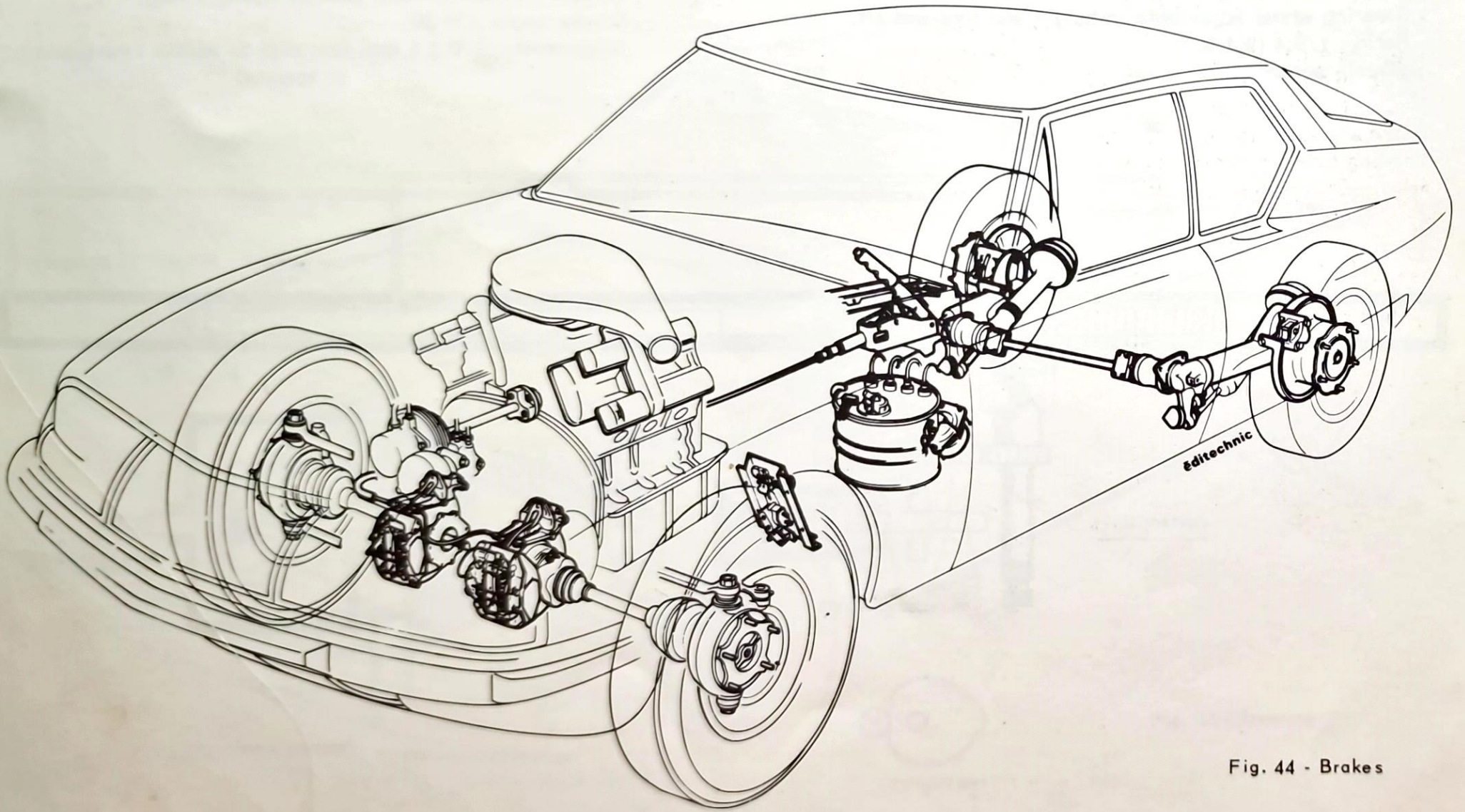

Fig. 44 - Brakes

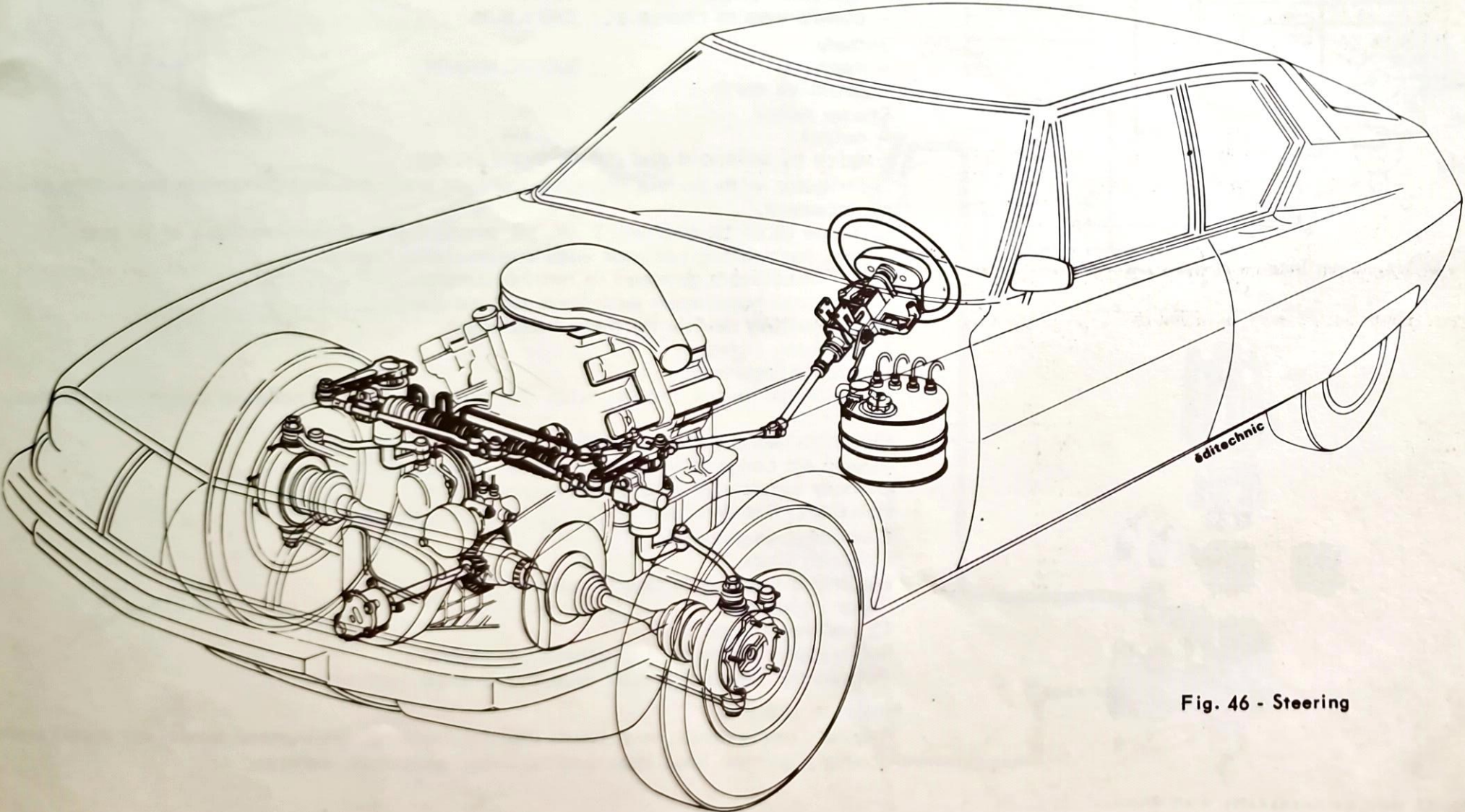

Fig. 46 - Steering

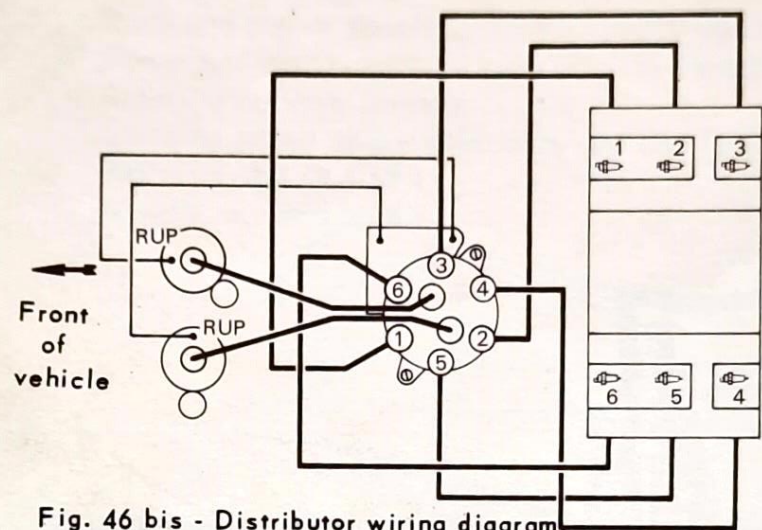

Fig. 46 bis - Distributor wiring diagram.

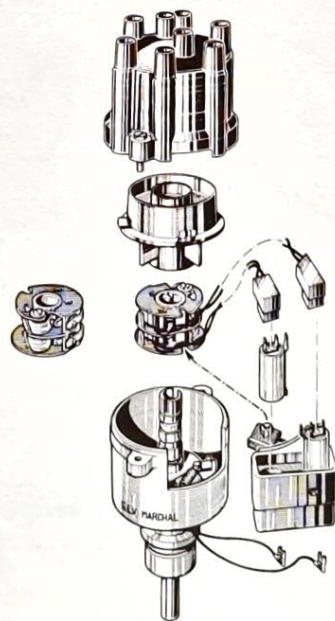

Fig. 46 ter - Twin-cassette distributor.

Electrical equipment

Voltage 12V

Alternator

- maximum output : 780 W
- commences to charge at : 670 r.p.m.

Battery

- capacity : 300/70 amp/hr
- negative earth

Starter motor

- output : 1.17 kW
- drive by solenoid and pre-engaged pinion.

Distributor with double cassette contact breakers and condenser permitting simple replacement.

12 fuses (9 of 16 amp and 3 of 10 amps) and 2 circuit-breakers of 30 amp.

2 fans for cooling radiator with thermostatic control.

6 Q.I. headlamps grouped in two housings.

Directional headlamps with independent control.

Self-levelling device for main headlamps.

2 reversing lights.

Foglamps (optional)

Windscreen wiper motor with 2 speeds and adjustable intermittent operation device.

Electrical windscreen washer.

Forced air conditioning by rheostat (4 speed).

Window winders electrically controlled.

Headlamp flashers and horns. (2 HF and 2 horns)

Electronic tachometer

Electric clock.

Electrical heating to rear window.

Cigar lighter.

12 warning lamps.

Radio (optional) with 3 speakers and mixer.

Accessory terminal (under ashtray) 6 amps maximum.

Interior lighting :

Engine compartment, rear boot, interior lighting, instrument panel, air conditioning control, ignition key, map reading lamp, glovebox, ashtray.

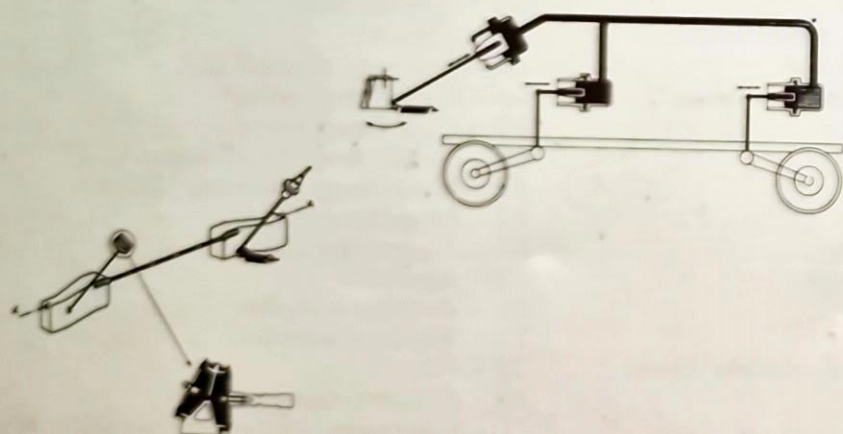
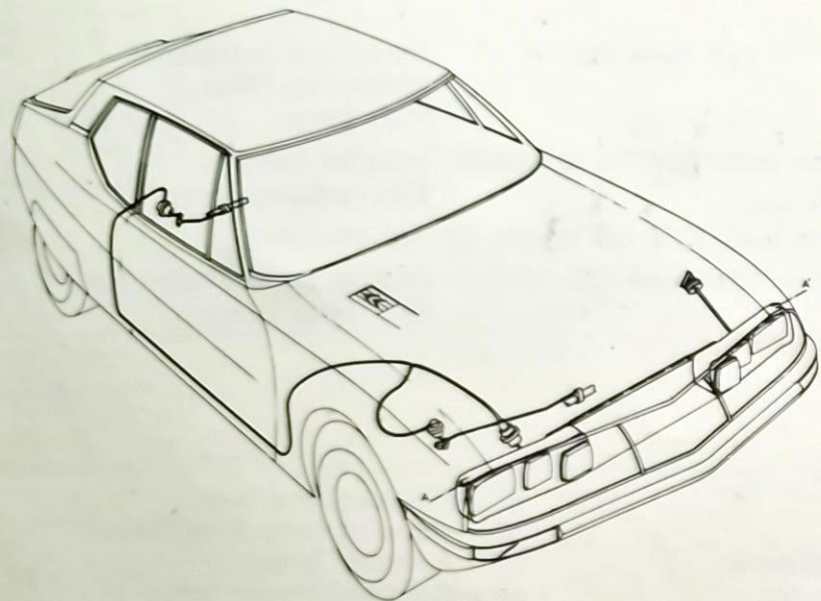

Fig. 47 - Self-levelling control of headlamps

LEFT-HAND TURN

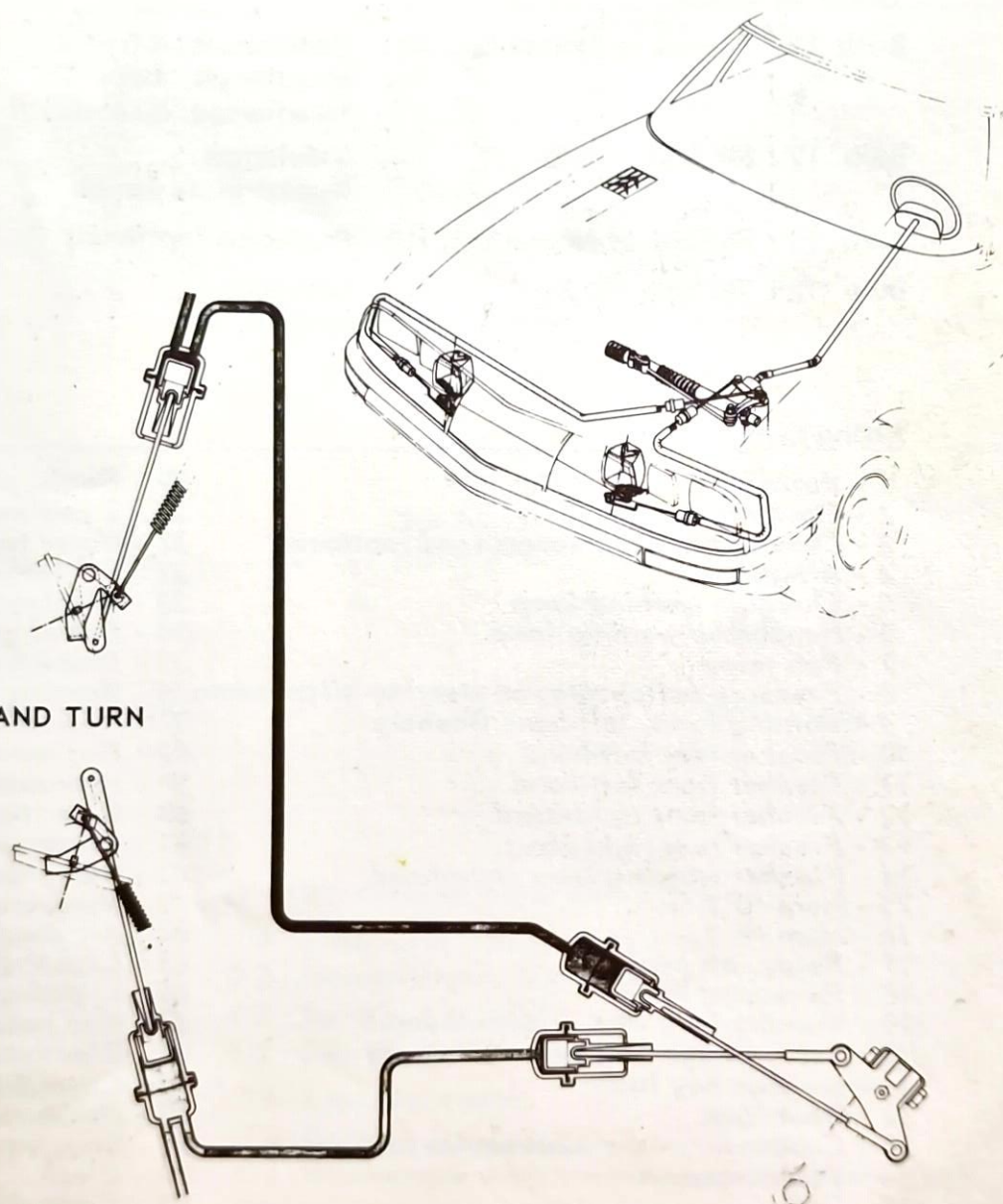

Fig. 47 bis - directional control of headlamps

Table of bulbs

Bulb 12V Philips or Norma Q.I. H1	Headlamps, dip Headlamps, main Headlamps, directional	Bulb 12V 21W type P25/1	Direction indicators Reversing lamp Stop lamp
Bulb 12V 5W type R19/5	Sidelamps Numberplate lamps	Festoon bulb 12V 7W length 38	Interior lighting Map reading lamp
Bulb 12V Philips or Norma Q.I. H2	Fog lamps (optional)	Festoon bulb 12V 4W length 38	Ashtray lamp
Bulb 12V 2W type T8/2	Glovebox Ignition key	Bulb 12V 10W type R19/10	Engine compartment lamp Rear boot lamp

Wiring diagram

1 - Battery	29 - Petrol pump	57 - Numberplate lamp	} Lighting
2 - Starter motor	30 - 2 cooling fans	58 - Warning lamp side lamps	
3 - Condenser, radio suppressed (optional)	31 - Water temperature indicator	59 - Ashtray lamp	
4 - Alternator	32 - Oil temperature indicator	60 - Air conditioner lamp	
5 - Charging warning lamp	33 - Warning lamp, fuel minimum	61 - Instrument panel	
6 - Handbrake warning lamp	34 - Petrol gauge indicator	62 - Oil temperature indicator fuel temperature	
7 - Fan relay	35 - Brake wear	63 - Tachometer	
8 - Pressure switch relay on steering-oil pressure	36 - Warning lamp check	64 - Clock	
9 - Warning lamp, left-hand flashers	37 - Hydraulic pressure, front brakes	65 - Lamps, dipped Q.I.	
10 - Flasher rear left-hand	38 - Engine oil pressure	66 - Headlamp relay	
11 - Flasher front left-hand	39 - Hydraulic pressure rear brakes	67 - Fog lamp relay	} Side and Tail Lamps
12 - Flasher front right-hand	40 - Water temperature	68 - Additional headlamps Q.I.	
13 - Flasher rear right-hand	41 - Windscreen wiper	69 - Headlamp warning lights	
14 - Flasher warning lamp right-hand	42 - Delay device	70 - Headlamps Q.I.	
15 - Horn N° 1	43 - Windscreen washer	71 - Fog lamp Q.I.	
16 - Horn N° 2	44 - Air conditioner relay	72 - Air horn	
17 - Relay, air horn	45 - Lighting under bonnet	73 - Window winder	
18 - Reversing lamp	46 - Lighting, glovebox	74 - Window winder	
19 - Warning lamp rear window heater	47 - Map reading lamp	75 - Fan	
20 - Rear window heater	48 - Electrical aerial and control relay	76 - Electro compressor	
21 - Ignition key lamp	49 - Cigar lighter	77 - Pressure switch on steering oil pressure	
22 - Boot lamp	50 - Radio receiver	78 - Mechanical liaison	
23 - Condenser, radio suppression (optional)	51 - Stop lamp	79 - Voltage regulator + charging warning light relay	
24 - Tachometer	52 - Clock		
25 - Coil	53 - Front right-hand		
26 - Distributor	54 - Rear right-hand		
27 - Coil	55 - Front left-hand		
28 - Condenser, radio suppression (optional)	56 - Rear left-hand		

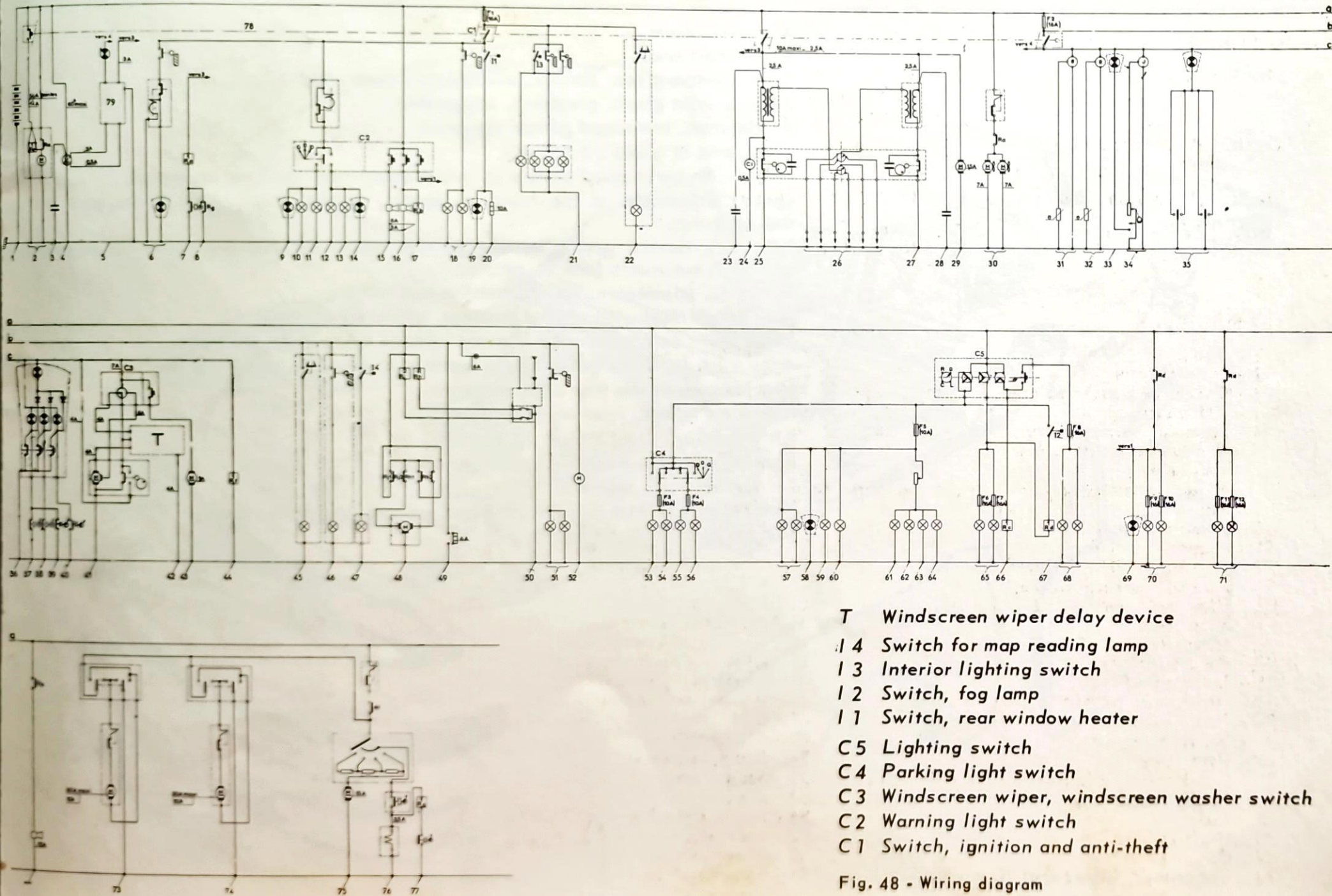

- T** Windscreen wiper delay device
- I 4** Switch for map reading lamp
- I 3** Interior lighting switch
- I 2** Switch, fog lamp
- I 1** Switch, rear window heater
- C 5** Lighting switch
- C 4** Parking light switch
- C 3** Windscreen wiper, windscreen washer switch
- C 2** Warning light switch
- C 1** Switch, ignition and anti-theft

Fig. 48 - Wiring diagram

4 seater coupe.

Mono shell body.

Door window glass, convex, electrically controlled.

Quarter light glass, pivoting, adjustable.

Windscreen, laminated (tinted optional).

Total area of glass : 2.735 m²

Locks with burst-proof device to avoid accidental opening on impact.

Seats, adjustable at the front, in length, height, inclination of the seat and of the backrest.

Fold-back device giving access to rear seats without disturbing the adjustment and with automatic lock on return.

Headrest, adjustable, for inclination and height.

Rear bench seat with central armrest, adjustable.

Three point safety harness, instant release by lever at the front.

Anchorage for three point safety harness at rear.

Map pockets in the four side armrests.

Rear view mirror, interior, day-night.

Air conditioning by forced air system.

Heating with thermostatic adjustment.

Air conditioner, optional.

Boot lid maintained in position by telescopic pneumatic stays.

Volume of rear boot : 428 dm³

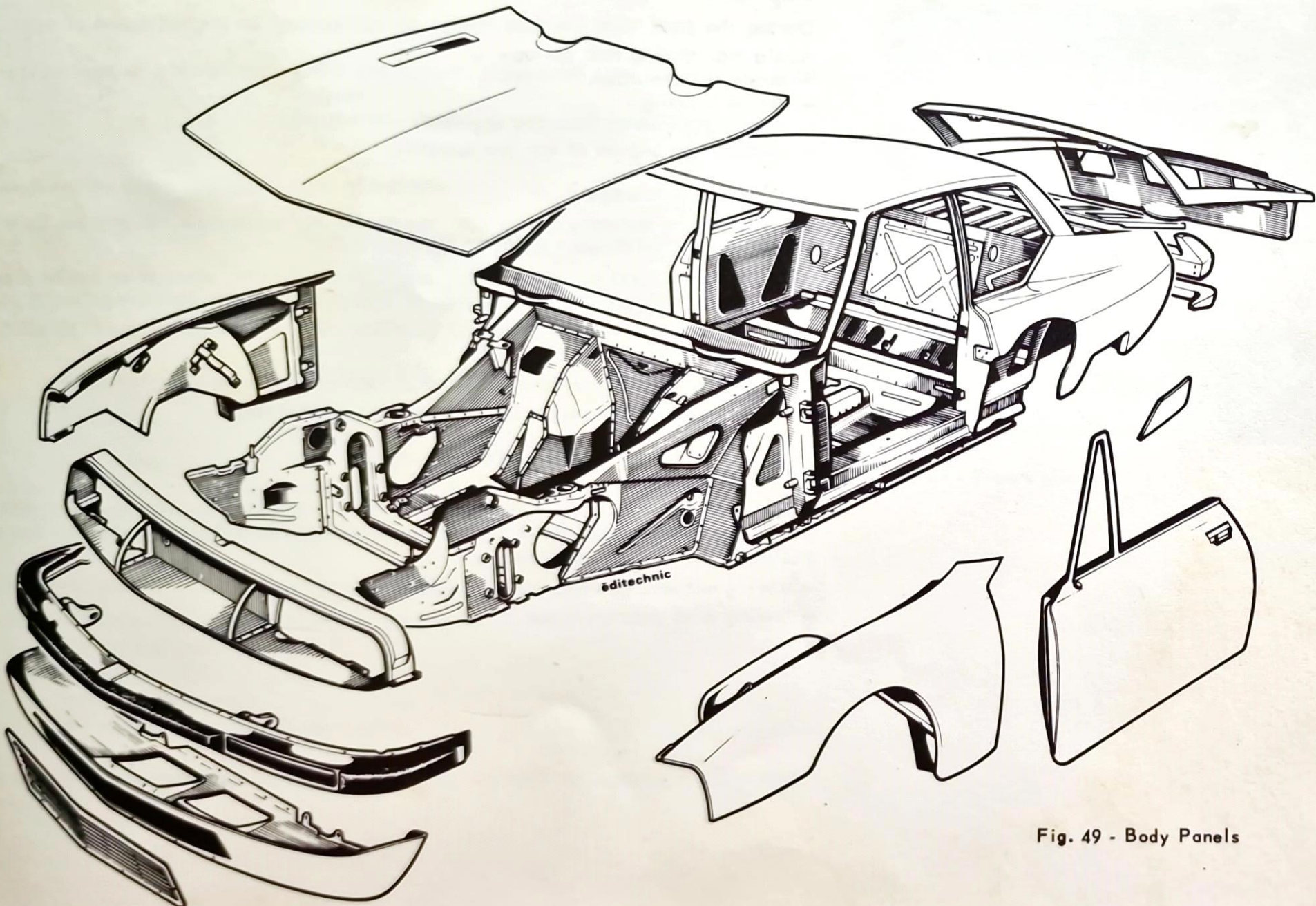

Fig. 49 - Body Panels

Identification

- Situation
- Makers plate (chassis No-plate) : under the bonnet, right-hand side on the front side member,
- Engine plate : On the engine crankcase, left-hand side.
- Information
- On manufacturers plate : type of vehicle
series
chassis number
total weight, laden
total weight, laden with trailer
- Stamped on body : type of vehicle
series
number in type series
- Engine plate : make
engine type
manufacturers number

In France, the type of car and the chassis number are also indicated on the grey card (registration document).

Ordering spare parts

- Indicate on all orders :
- the type of vehicle
 - the series
 - the chassis number
 - the type and number of the engine.

A spare parts catalogue and a repair manual are on sale at Agents and Concessionaries.

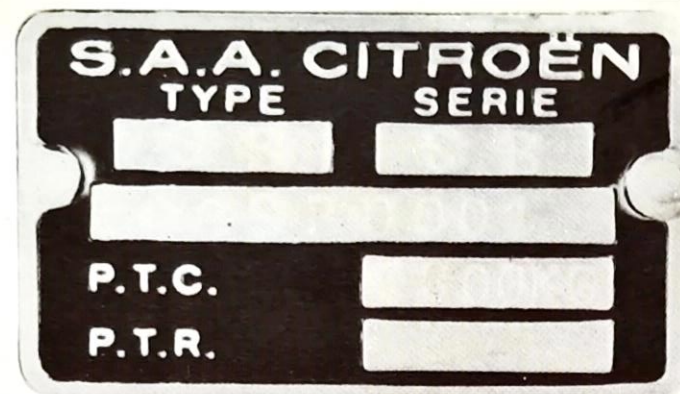

Fig. 50 - Chassis number plate



Fig. 51 - Engine plate

- A** Access to rear seats 8
 Air conditioning 16
 Air (temperature) 16
 Antifreeze 23
 Anti theft 10
 Armrests 18
 Ashtrays 18
- B** Battery (level) 20
 Battery (maintenance) 23
 Battery (replacement) 34
 Battery charging (warning light) . . . 2
 Bodywork (characteristics) 52
 Bodywork (maintenance) 24
 Bonnet 7
 Brakes 12-44
 Bulbs (replacement) 30
 Bulbs (Instrument board) 50
- C** Capacities On back of manual
 Caravanning -54
 Changing round the wheels 22
 Chassis number 2-55
 Checks (at 1000 km. (600 miles) . . . 54
 Checking red warning lamps 2
 Checks before running
 On back of manual
 Choke 10
 Cigar lighter 2
 Cleaning the glass 24
 Cleaning the trimming 26
 Clutch 40
 Combined anti-theft ignition starter 10
- D** Demisting 17
 Defrosting 17
 Direction indicators 14-30
 Direction indicator lights 14-30
 Differential 40
 Doors (opening) 6
 Draining hydraulic installation . . . 34
 Driving position 9
- E** Electrical installation 48
 Electrical connections 51
 Electrical wiring 51
 Electrical diagram 51
 Electric clock 2
 Engine number 55
 Engine plate 55
 Engine characteristics 38
 Engine oil pressure 2
 Engine oil (filling) 20
 Engine oil (warning lamp and
 thermometer) 2
 Electronic tachometer 2
- F** Fog lamp 15-30
 Front controls 2
 Fuel (warning lamp and gauge) 2
 Fuel (filling) 7
 Fuel gauge 2
 Fuse box 33
 Fuses 33
- G** Gear lever 12
 Gear changing 12-40
- H** Gearbox 40
 Gears (control) 12
 Glass (cleaning) 24
 Glass (opening) 7
 Glove box 6
 Guarantee 54
 Ground clearance (adjustment) 12
- I** Headlamps (control) 15
 Headlamps (adjustment) 32
 Headlamp flasher 14
 Headrest 8
 Heating 55
 Height corrector 12
 Horns 14
 Hydraulic installation 41
 Hydraulic Fluid, green "LHM" 20
 Hydraulic fluid pressure 2
 Hydraulic fluid (filling) 20
 Hydraulic fluid (warning lamp) 2
- J** Identification of the car 55
 Incidents 28
 Instruments on panel 2
 Intermittent action of
 windscreen wiper 14
 Interior lighting 18-31
 Instrument board 5
 Ignition 10
- K** Keys 6

INDEX

L	Levels (checking and topping up)	20	Replacing a fuse	33	Tachometer	2		
	Level of fuel (warning lamp and gauge).	2	Replacing a bulb	2	Temperature of forced air supply	16		
	Lighting switch	15	Replacing a wheel	30	Temperature of oil	2		
	Light signals	14	Rear view mirror	9	Temperature of water	2		
	Locks	6	Retouching the paintwork	25	Towing	34		
	Locking devices	6	Reversing	12	Tyres	22		
			Running in	54	Tyre pressures at back of manual			
M	Map reading lamp	18	Rear seats (access)	8	Transmission	40		
	Map pockets	18	Radiator maintenance	23	Tar stains	25		
	Maintenance	22	Radiator (level)	20	Trimming (cleaning)	12		
N	Numbers (cold stamped)	55	S	Spare parts (ordering)	55	V	Valves	38
O	Ordering spare parts	55		Seat Belts	9		Ventilation	16
	Outside lighting	15-30		Seats (adjustment)	8	W	Warning lamps	2
P	Paint damage	25		Stopping engine	10		Wear of brake pads	2
	Parking lights	15-30		Sparking plugs	34		Weights	36
	Plexiglass (perspex) (cleaning)	24		Starting the engine	10		Warning lamp cluster	2
	Principal dimensions	44		Straight line return device (steering)	13-46		Wheel changing	28
	Points (gaps)	34		Stains, tar	25		Water (temperature)	2
	Polishing	25		Stains, upholstery	26		Water (checking and re-filling)	20-23
R	Removing trimming	26		Steering wheel (adjusting)	9		Washing	24
	Rear window (heating)	17		Seats	8		Windscreen washer (control)	14
	Rear boot	6		Starter motor	10		Windscreen washer (filling)	20
	Replacing a battery	34		Seat back rest (adjustment)	8		Window winders (electric)	7
	Replacing a sparking plug	34		Stopping distances	10		Wheels (replacement of)	28
				Steering	13-46		Windscreen washer	14
				Speed indicator	2			
				Side windows	7			
				Suspension	42			
				Sun visor	18			
				Speedometer	2			
			T	Technical characteristics	36			

SERVICING DATE SUMMARY

- Tyres** : Michelin 195/70 VR-15X (tubeless).
Pressures – Front 2.2 bar (32 psi.)
– Rear 2 bar (29 psi.)
– Spare 2.4 bar (35 psi.)
- Fuel** : Premium (4-star), 97-99 octane.
– Capacity : 90 litres (20 gall. Imp. 24 gall US)
- Oil** : TOTAL GTS 20W50
For very cold countries : TOTAL GTS 10W30.
- Hydraulic System** : Green hydraulic fluid, TOTAL "LHM".
Capacity 5.4 litres (9 1/2 pts. Imp. 11 1/2 pts. US).
- Radiator** : Water with TOTAL anti-freeze.
Capacity : – 13 litres '23 pts. Imp. 27 1/2 pts. US).
- Screen Washer** : Water, to which may be added.
– all the year round, an additive such as "Stop Clair".
– in winter, an additive such as "Stop-Gel".
- Battery** : 12V - 300/70 AH.
Top up with distilled water, never add acid.
- Spark Plugs** : BOSCH W200. T 30
Electrode gap : – 0.6 to 0.7 mm (0.024 to 0.028 in).
- Bulbs** : See Table on p. 50.

CHECKS BEFORE STARTING

Levels : fuel
engine oil
radiator
LHM fluid
battery
Screen washer

Operation of : Red Warning Lamps
Horns
Headlamp flasher
Exterior Lighting
Direction indicators
Stoplamps

Various : Position of driving mirrors
Tyre pressures